

M01510

55

DGCRCE 0001

POTTER

Keith

TEC-S/EST-LEA

CERN COURIER

International journal of high energy physics

VOLUME 38

2

MARCH 1998



More choice than ever before with new, simple MidiVac.

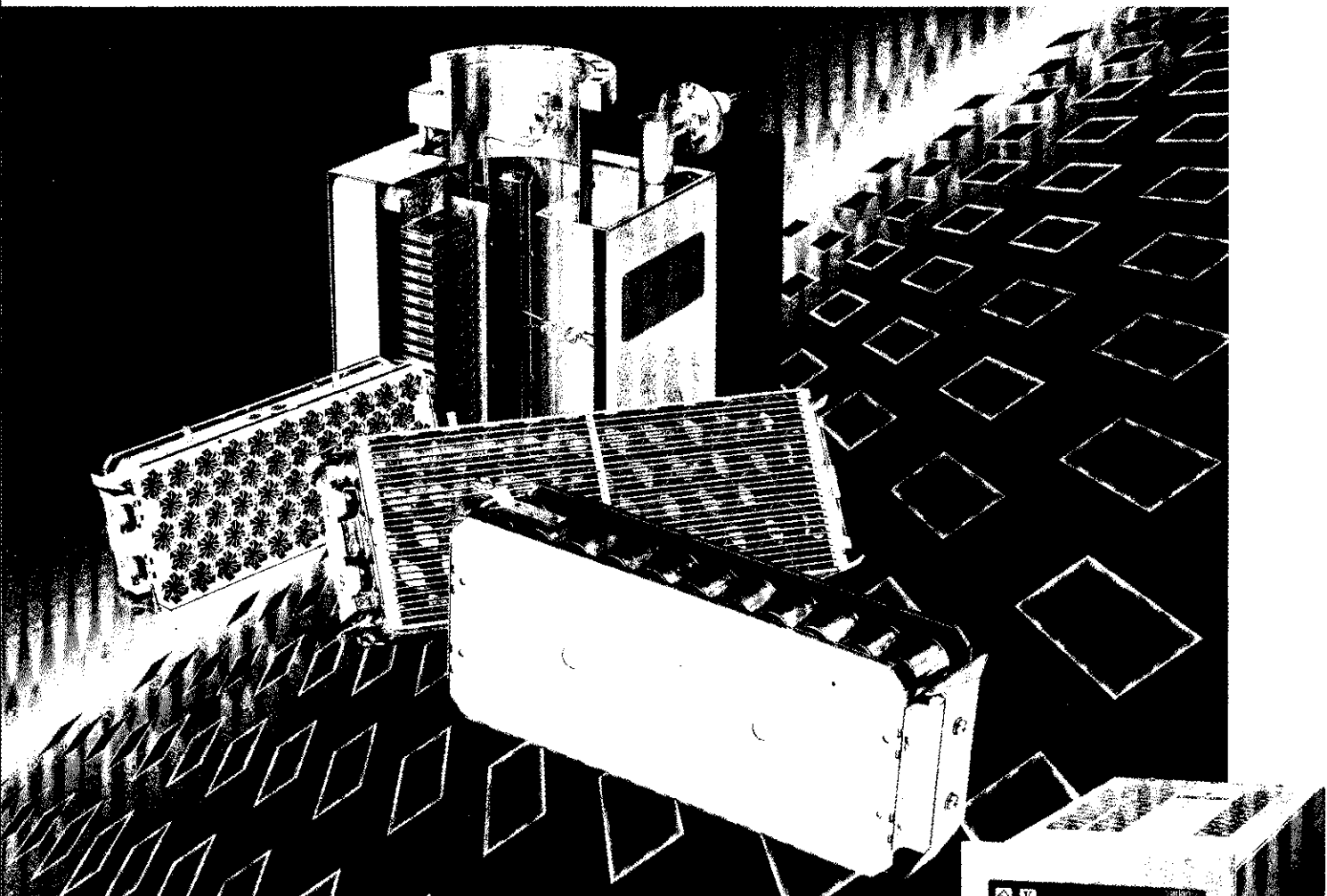

With the addition of MidiVac to our series of ion pump controllers, Varian now offers more choice and flexibility than ever before. Designed to power any size and type of ion pump, MidiVac features single- or dual-voltage outputs for simultaneous control of two ion pumps. With the latest in design features, it can be interfaced with a computer. Yet, it is simple and easy to operate.

Now you can select just the right controller to fit your specific application whether it is the low-cost MiniVac, the ultra-versatile MultiVac, or the new MidiVac.

Varian also offers the broadest range of ion pumps available. With Diode, Noble Diode, and StarCell pumping elements, each Varian VacIon Plus pump is optimized to pump specific gases.

Look to Varian for vacuum made simple. Whatever your pumping needs, our VacIon pumps and controllers offer a complete solution. For more information, see us at <http://www.varian.com>, or call us at:

1-800--8VARIAN in the U.S.
39.11.9979111 (Italy) in Europe
81.3.52321253 in Japan



varian 

Advertising enquiries

Europe

Micheline Falciola
Advertising Manager
CERN
CH-1211 Geneva 23, Switzerland
Tel.: +41 (22) 767 4103
Fax: +41 (22) 782 1906

Rest of the world

Guy Griffiths
Advertising Manager, USA
International Publishers Distributor
820 Town Center Drive
LANGHORNE PA 19047
Tel.: (215) 750-2642
Fax: (215) 750-6343

Distributed to Member State governments, institutes and laboratories affiliated with CERN, and to their personnel.

General distribution

Jacques Dallemagne
CERN, 1211 Geneva 23, Switzerland

In certain countries, to request copies or to make address changes contact :

China

Chen Huaiwei
Institute of High Energy Physics
P.O. Box 918, Beijing,
People's Republic of China

Germany

Gabriela Heessel or Astrid Nagel
DESY, Notkestr. 85, 22603 Hamburg 52

Italy

Mrs. Pieri or Mrs. Montanari
INFN, Casella Postale 56
00044 Frascati, Roma

United Kingdom

Su Lockley
Rutherford Appleton Laboratory,
Chilton, Didcot, Oxfordshire OX11 0QX

USA/Canada

Janice Voss
Creative Mailing Services
P.O. Box 1147
St. Charles, Illinois 60174
Tel.: 630-377-1589 / Fax: 630-377-1569

CERN COURIER is published monthly except January and August in English and French editions. The views expressed in the Journal are not necessarily those of the CERN management.

Printed by: Drukkerij Lannoo nv
8700 Tielt, Belgium

Published by:

European Laboratory for Particle Physics
CERN, 1211 Geneva 23, Switzerland
tel.: +41 (22) 767 61 11,
telex: 419 000 CERN CH,
telefax: +41 (22) 767 65 55

CERN COURIER only:
tel. +41 (22) 767 41 03,
telefax +41 (22) 782 19 06

USA: Controlled Circulation
Periodicals postage paid at St. Charles,
Illinois

ISSN 0304-288X

Volume 38
No. 2
March 1998

Covering current developments in high energy physics and related fields worldwide

Editor: Gordon Fraser
CERN.COURIER@ CERN.CH

Production and Advertisements:
Micheline Falciola
Micheline.Falciola@cern.ch

Advisory Board: E.J.N. Wilson (Chairman), E. Lillestol,
M. Neubert, D. Treille; with L. Foà,
J. Ferguson

World Wide Web <http://www.cern.ch/CERN/Courier/>

Around the Laboratories

1

CERN: LHC experiments march on
Major experiments take shape

3

X-raying muon chambers
Tomography in action

4

Thirty years of ISOLDE
Isotope source anniversary

7

KEK: C-band klystron achieves 50 MW

8

BROOKHAVEN: Muon magnetism sub-parts per million

11

Near the beam: Getting in close

12

PROTVINO: Efficient crystal extraction

13

Hunting down the quark-gluon plasma
Quark Matter conference report

Physics monitor

16

Middle East: More bridges

17

Physics and detectors for a linear electron-positron collider

18

World science at CERN

18

Feynman in New Zealand

20

Bookshelf

24

People and things

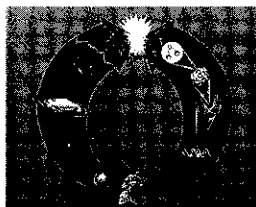

Cover illustration: The two frontiers of physics - one looking outwards through planetary systems, galaxies and clusters of galaxies towards the edge of the Universe, the other looking inwards to the small scale structure of the microcosmos, culminating with quarks. These two frontiers, one going back in time by traversing the immense distances of outer space, the other probing the micro-mechanisms at work deep inside matter, eventually converge at the Big Bang.

KAPTON® A high performance base for demanding flexible circuits

■ The remarkable properties of KAPTON® Polyimide Film from DuPont make it the ideal base material for flexible circuitry. Excellent performance characteristics at extremes of temperature and unique physical and dielectric properties have made KAPTON® the material of choice in engineering design for over 30 years.

The new KAPTON® TAB-EN, with its tailored dimensional prop-

erties to copper, and KAPTON® KJ/EKJ, a thermoplastic polyimide film adhesive/composite, offer new design capabilities whilst at the same time maintaining their inherent radiation resistance and their physical and chemical properties.

To find out more about KAPTON® films for flexible circuits call or write.

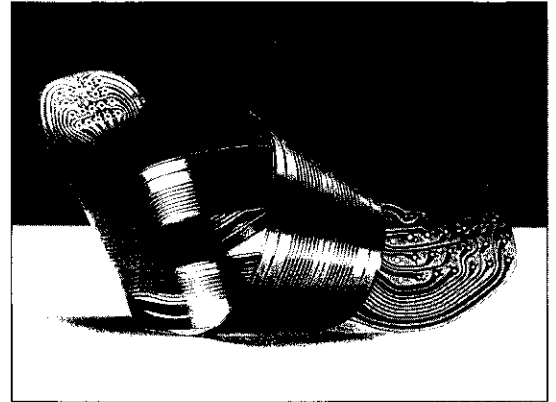

Solving engineering problems at every level.



Kapton®
Polyimide film

® DuPont registered trademark

Du Pont de Nemours, KAPTON® Films, Lahnstrasse 7, D-61273 Wehrheim, Germany. Tel. +49 6081 981573. Fax +49 6081 981574. Internet: Guenter.Forster@deu.dupont.com

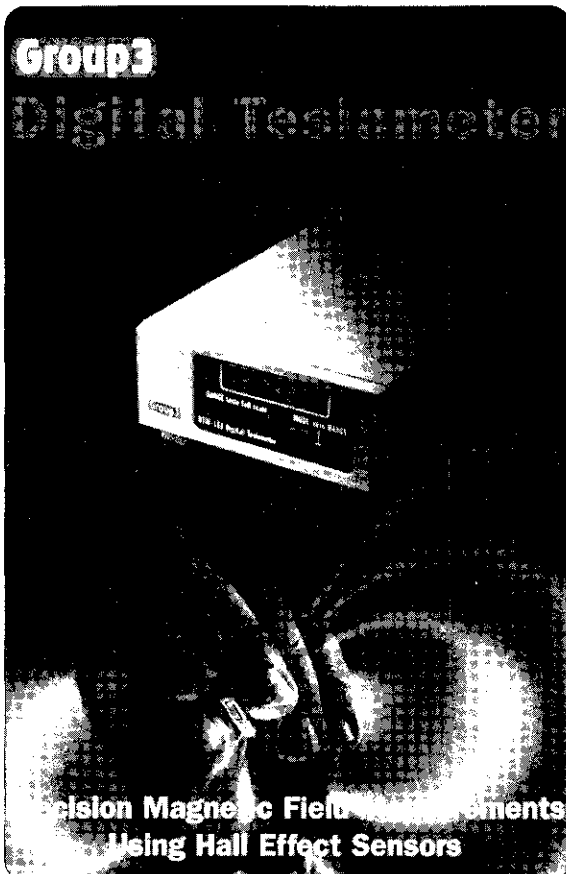

NEW!

Group3 introduces the DTM-151

The new Teslameter Features

- Outstanding accuracy
0.01% total system accuracy (Probe + Teslameter).
- Negligible thermal drift
typically less than 5ppm/°C, with excellent long term stability.
- High resolution
1 part in 600,000 (7 digit display) - resolves to 0.0000001 T on serial output.
- Small probe size
1mm x 0.5mm active area on smallest probes - ideal for precision mapping.
- Wide range probes
one small probe covers whole range up to three T - no need to change probes.
- Communication options are serial data via fiber optics and RS232, or GPIB (IEEE-488).
- Noise immunity
DTM-151 incorporates many features to reduce the effects of electrical transients. Noise-free transmission of data - even across high voltage differences.



Danfysik A/S · DK-4040 Jyllinge · Denmark
Tel. international: +45 4678 8150 · Fax: +45 4673 1551 · e-mail: dfysik@inet.uni-c.dk
In USA: GMW Associates · Tel.: (650) 802-8292 · Fax: (650) 802-8298
In India: Transact India Corp. · Tel.: (22) 285-5261 · Fax: (22) 285-2326

Around the Laboratories

In the ATLAS – inside a major experiment for CERN's LHC collider.

CERN LHC experiments march on

The signing of the major CERN/US agreement at the end of last year (January, page 1) underlined the US commitment to CERN's LHC proton collider now under construction and scheduled to come into operation in 2005. The LHC will use the 27-kilometre tunnel built for the LEP electron-positron collider in the 1980s.

The \$531 million US contribution to the LHC includes \$200 million from the US Department of Energy (DOE) for components and materials for the LHC accelerator itself, together with \$331 million from the DOE (\$250 million) and the US National Science Foundation (\$81 million) for the massive ATLAS and CMS general purpose detectors. Last month's article summarized progress for the LHC machine. This time the accent is on progress towards the two big detectors.

LHC-oriented detector research and development at CERN formally began when the Detector Research and Development Committee (DRDC) was set up in 1990 to guide new ventures, and the valuable portfolio of new techniques emerging from this effort was inherited by the LHC experiments as they moved from initial proposals to large, highly autonomous collaborations. These high technology approaches have been assiduously sharpened to meet specific demands and final solutions are at least imminent, if not actually ready.

Such large projects are resource hungry, and in these cost-conscious times LHC expenditure is carefully

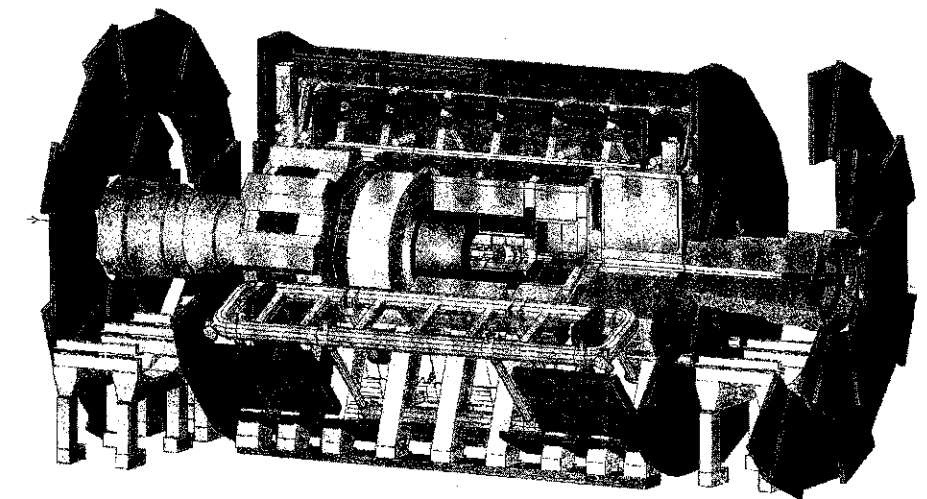

monitored by the LHC Cost Review Committee (CORE), by Resource Review Boards, and by the collaborations themselves. Although most of the cost is underwritten by the participating research institutes, a ceiling of 475 million Swiss francs has been imposed by CERN on both ATLAS and CMS.

In addition to the ATLAS and CMS general purpose detectors, the LHC research programme also includes the ALICE detector for studies of heavy ion collisions, and LHC-B to investigate the production of particles containing heavy quarks. ALICE was formally approved last year (April 1997, page 4), while LHC-B will soon submit a full technical proposal.

The CERN contribution to the construction of all LHC experiments is worth 207 million Swiss francs (1997 prices), together with 2350 man-years of effort.

ATLAS

The ATLAS collaboration now attracts more than 1700 scientists and engineers from 144 research centres. Preparations for the huge detector, with its superconducting toroidal magnet extending over a length of 26 metres and a diameter of 20 metres, change gear this year. This follows the green light to begin civil engineering work for the vast new ATLAS underground cavern in the LEP/LHC ring across the road from CERN's Geneva site (but still in Swiss territory), and construction approval for many parts of the detector.

For the large ATLAS toroid, the specially designed superconducting cable is now being fabricated, and a 9-metre-long segment of one magnet barrel coil is being designed for delivery in 1999 and which will

Cutaway view of the CMS detector for CERN's LHC proton collider, showing the outer four layers for detecting muons (interleaved with three layers of iron), the central calorimeters and the inner tracking system.

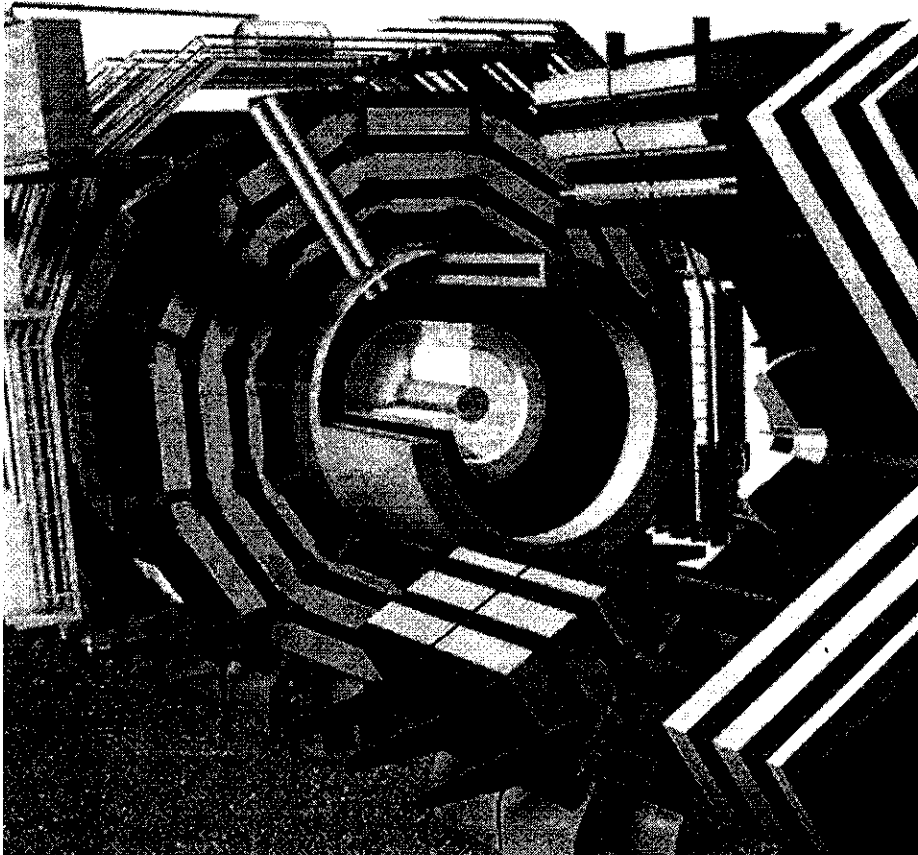

include all the critical components and fabrication methods as the final coils. Engineering for the muon chambers to be interleaved with the magnet is being finalized.

Deep inside the main magnet, the inner ATLAS detector will use a 2 Tesla solenoid for tracking. Design and tendering for this inner magnet is being handled by the Japanese KEK Laboratory, and a contract for superconducting cable has already been placed.

The innermost part of the ATLAS tracker will use layers of high precision semiconductor pixels and strips, surrounded by straw tubes to measure the outer parts of the trajectories. This year will see further consolidation of design and technology for these semiconductor detec-

tors, while construction of a final prototype straw tracker is well advanced.

For ATLAS calorimetry, prototyping for both the liquid argon electromagnetic and hadronic endcap parts as well as the scintillating tile hadronic part are well underway (April 1997, page 5), with series production starting this year.

CMS

CMS now attracts more than 1600 scientists and engineers from 151 research centres. The CMS underground caverns will be excavated at LHC/LEP Point 5 in France, diametrically opposite ATLAS. To pave the way for this

work, a comprehensive environmental impact study has been painstakingly prepared for the French authorities.

The huge effort towards the creation of the CMS detector has passed major milestones in 1997. Two subsystems, the magnet and the hadronic calorimeter (October 1997, page 10) had their technical designs approved. The magnet, a 4 tesla superconducting solenoid, 13 metres long and 6 metres in diameter, is now well under way and test samples of superconducting cable have been fabricated. This year will see the start of manufacturing of the 14,500 tons of barrel and endcap iron yokes. The hadronic calorimeter will have its first full-scale prototype in a CERN test beam later this year.

CMS also submitted, at the December LHC Experiments Committee session, two new technical design reports for the muon system and the electromagnetic calorimeter. Electromagnetic calorimetry will use 80,000 lead tungstate crystals. Crystals from Russia and China have given consistent and reproducible results which open the way to preproduction in Russia this year. Muon detection will use three technologies (Drift Tubes "DT" in the barrel and Cathode Strip Chambers "CSC" in the endcaps for precise position measurements and Resistive Parallel Plate Chambers in both regions to complement the trigger). Full scale prototypes of DTs and CSCs have been constructed and tested.

Major progress has also been made in developing low-cost silicon microstrip detectors, novel microstrip gas chambers and robust pixel detectors for the CMS tracking system. The ensuing technical design report will be submitted to the LHC Experiments Committee in April.

For optimal performance, muon detectors have to be precision aligned and surveyed. This shows a pre-production X-ray tomography unit at CERN for the muon chambers of the ATLAS experiment. Visible on the left are the laser interferometers to control the X-ray beam position. Below is a detail showing the movable cart carrying the X-ray sources.

Preparations for these major LHC experiments proceed in lock step to ensure that the detectors are up and running to intercept the first LHC beams.

X-raying muon chambers

One of the paradoxes of elementary particle physics is that to probe deeper into the underlying structure of matter requires larger and larger apparatus. Large accelerators take particle beams to the higher energies needed to drill deeper inside the bedrock structure of matter, while the detectors have to be large to unravel the progressively more complex interactions that these beams produce.

Nowhere will this be more true than at CERN's 27-kilometre LHC proton collider, where the ATLAS detector, as high as a ten-storey building, will be constructed in a vast underground cavern.

One of the main features of ATLAS is its muon tracking, and layers of precision muon detectors, including 1200 Monitored Drift Tube chambers, make up the outer ATLAS envelope, covering a total surface area of some 5500 square metres, the area of a modest football pitch. The key to effective muon spectroscopy is precision, which requires in turn that the muon detector system has to be first aligned and periodically surveyed with pinpoint accuracy.

The drift chambers are made of aluminium tubes 30mm diameter and of 400 micron wall thickness, containing a 50 micron diameter central sense wire. The tubes are then aligned in layers and the layers

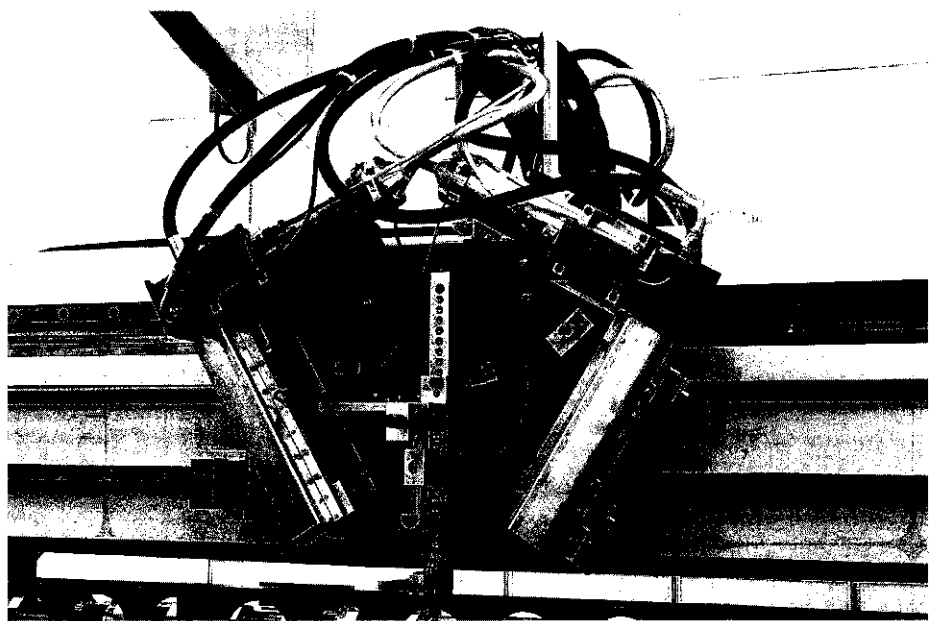
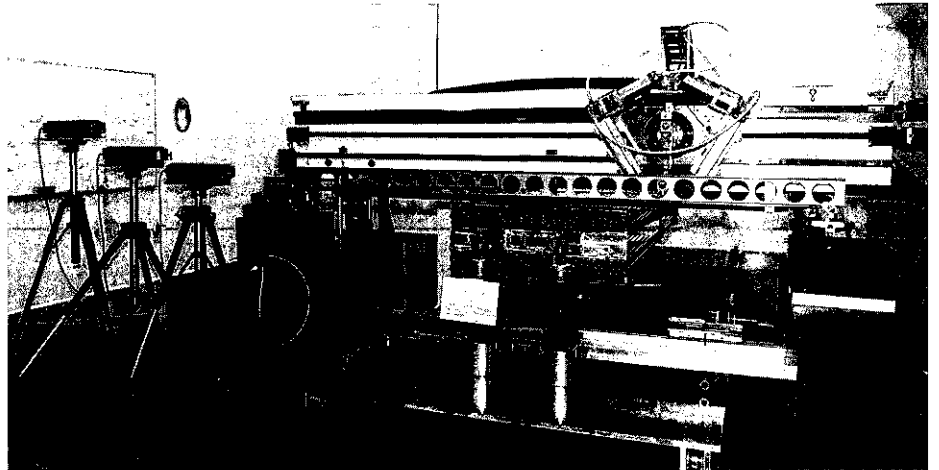

stacked three or four deep in multilayers. Two multilayers, together with an intermediate spacer structure, form a chamber.

To guarantee full ATLAS precision of some 50 microns, the hidden sense wires must be aligned to within 20 microns or less, and this for components several metres long. The position and any deformation of the chambers themselves are optically monitored. Constructing the ATLAS muon chambers thus amounts to a large scale industrial

project under stringent precision.

A prototype device for measuring the position of sense wires in the drift tubes was developed at the Joint Institute for Nuclear Research (JINR), Dubna, near Moscow, and the ATLAS team decided to adopt this approach. From 1992-4 a joint CERN-JINR team constructed a 600 mm scanning length prototype in which a narrow X-ray beam scans successive chamber 'slices', with the absorption profile recorded by a scintillator. The data provide projec-

CERN's ISOLDE on-line isotope separator is celebrating 30 years of operation. ISOLDE then: a beamline in first ISOLDE experimental hall in August 1967.

tive measurements, and stereo 'views' are possible if the X-ray beam is used at two different angles. The technique was able to attain 6 micron precision.

A CERN/ATLAS team led by François Rohrbach built a full-scale prototype for measuring the large muon chambers being built for ATLAS. To ensure such precision over the full 2.16 m range, the position of the X-ray beams is monitored using three interferometers. Improvements aim at increased precision control, shortening the scanning time and robotic control, so that production measurements can begin this summer.

As well as ensuring the success of ATLAS, this is another potential scenario for spinoff from particle physics.

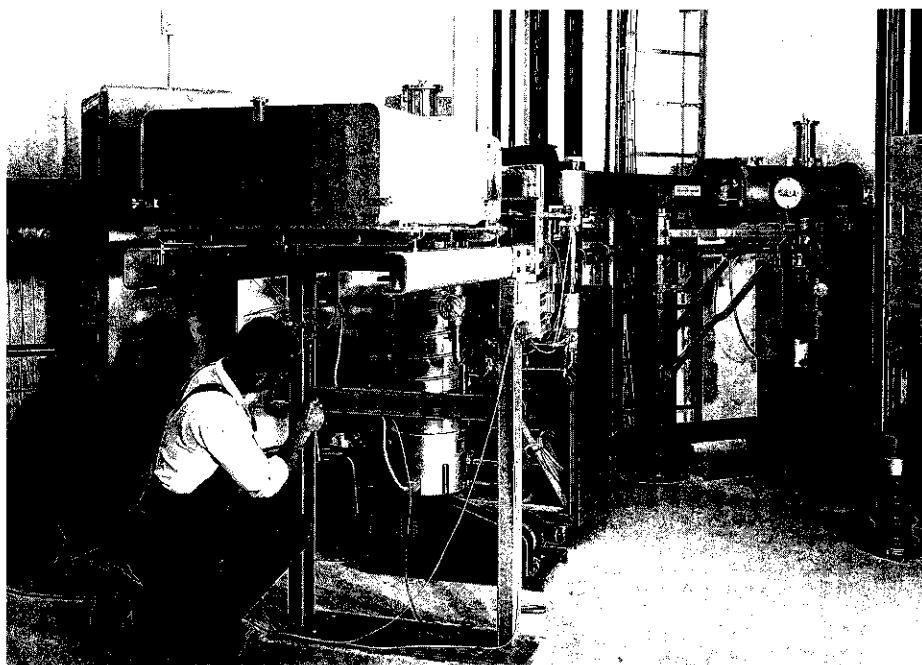

Thirty years of ISOLDE

The only thing which has been left unchanged is the name", said Gerhard Huber, chairman of the ISOLDE Collaboration, introducing a symposium to mark the 30th anniversary of CERN's on-line radioactive beam source. The symposium was a celebration of three decades of research ranging from nuclear structure to biomedicine.

Although concentrating mainly on past and recent achievements, the symposium was more than just a retrospective. Huber also took time to look forward with the news that the European Union has agreed to provide support for ISOLDE within the EU research framework. CERN's Director of Accelerators, Kurt Hübner, also looked to the future,

pointing to an assured programme to 2004, with the prospect of a higher energy primary proton beam in store as CERN gears up its accelerator chain in preparation for the Large Hadron Collider, LHC.

Bjorn Jonson of Chalmers University in Goteborg, whose career is so intertwined with ISOLDE that he once received an invitation addressed to Madame Isolde Jonson, was first to speak about research at the facility. He traced the development of nuclear structure research from the first beams in 1967, where isotopes of four elements were produced, to today where sophisticated ion source and target techniques are employed to cover well over half of the periodic table. Underlining ISOLDE's virtuosity, Jonson spoke of the study of octupole nuclear shapes in highly deformed nuclei such as radon-225, and the impressive array of measurements on the difficult to produce isotope argon-32.

The range of isotopes within

ISOLDE's repertoire, said Jonson, also allows studies to be made of nuclei which contain too many protons or neutrons so that they decay by simply 'dripping'. At the so-called proton dripline, rapid changes in deformation are seen and information can also be gleaned about nucleosynthesis through rapid proton capture. Amongst many other highlights Jonson chose to study was lithium-11, a nucleus with an extreme neutron excess leading to the effect that two loosely bound neutrons orbit in a halo. Lithium-11 has allowed ISOLDE researchers to learn about the neutron-neutron interaction and to study a pure quantum mechanical three-body system.

An impressive range of techniques developed or adapted for atomic physics at ISOLDE was discussed by Mainz's Ernst Otten, who elaborated on just a few. Fresh on the scene is the MISTRAL spectrometer (September 1997, page 20) designed to measure the masses of short lived isotopes. Last November, MISTRAL

Zero-flux™ measuring systems

Reliability and accuracy

SPECIAL
MEASURING
SYSTEMS



Sometimes a good eye and a steady hand are all you need. However, for measuring currents with high accuracy and reliability you need other qualities. You need a Zero-flux™.



HOLEC
Power
Protection

P.O. Box 4
7550 GA Hengelo
The Netherlands
Phone: +31 74 246 28 53
Fax: +31 74 246 26 78
e-mail: sales_sms@compuserve.com

www.holecups.com/sms

UNUSUAL

REQUESTS

Goodfellow is an established specialist supplier of small quantities of metals & materials for research, development, prototyping and design.

Our product range is renowned for being the most comprehensive of any source in the world.

Whilst we can't guarantee to make fairy tales come true, we can help with your unusual requests for materials. Contact us now for a copy of our new product guide and find out what we can do for you.

Goodfellow

Goodfellow Cambridge Limited
Cambridge Science Park, Cambridge CB4 4DJ
Great Britain
Telephone: +44 (0)1223 568 068
Fax: +44 (0)1223 420 639
E-mail: info@goodfellow.com
Web: www.goodfellow.com

ISOLDE now: the set-up at the latest hall just after its inauguration in 1992.

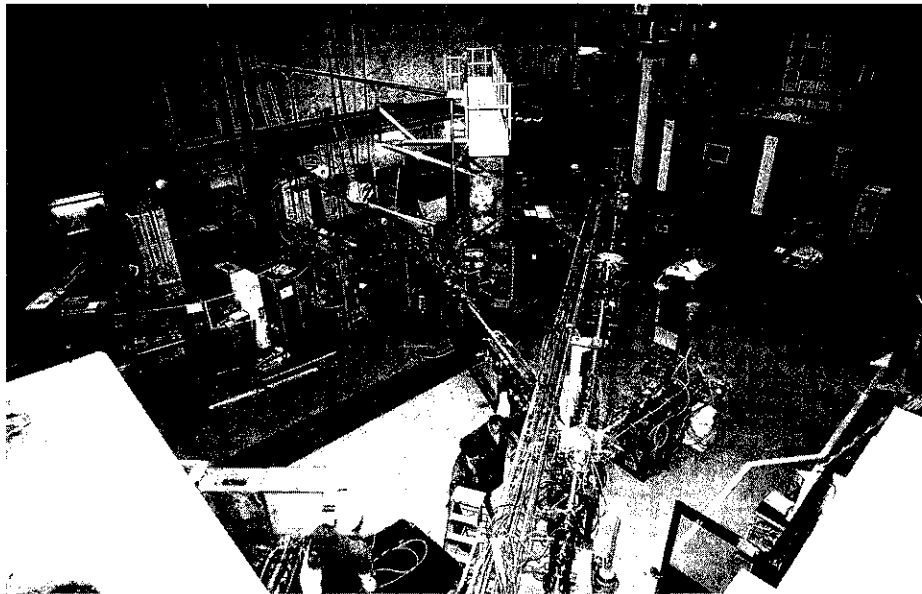

measured mass differences between isobars of mass 30 to one part in 100 000. MISTRAL complements the longer established ISOLTRAP experiment in which a series of Penning traps are cascaded to measure mass differences between more stable isotopes to an accuracy of one part in 10^7 . As well as providing direct information on nuclear structure effects, accurate mass values of very unstable isotopes are important for testing and improving nuclear models.

Laser spectroscopy has been one of the most successful atomic physics methods of investigating the shapes, spins, and magnetic or electric moments of radioactive isotopes. One of the most recent spin-offs of laser spectroscopy is the laser ion source. As well as providing extremely clean ion beams for important measurements in nuclear astrophysics (January, page 6), the laser ion source will also be used as to measure the hyperfine structure of unstable isotopes.

Manfred Deicher from Konstanz discussed ISOLDE's role in solid

state physics and life sciences. In solid state physics, radioactive isotopes are used to study the properties of surfaces, interfaces, and bulk materials, one topical example being hyperfine magnetic fields at selenium atoms on a nickel surface. These are much lower than fields in the bulk material, a phenomenon not currently explained by theory. Radioactive isotopes are also valuable in semiconductor physics for studying properties of dopants and impurities. For example, electrons or alpha particles emitted from a radioactive atom in a lattice are channelled by the lattice allowing the precise location of a dopant or impurity to be determined. Another example is the study of hydrogen in semiconductors. Hydrogen interacts with dopants, changing the electrical properties of the material.

An early success in life science came in 1978 when the element thulium was found to home in on cancer tumours in mice. Since then, ISOLDE has made important contributions to the development of Positron Emission Tomography (PET)

techniques (March 1995, page 2). A current example is in-vivo dosimetry using samarium. The isotope samarium-153 is used to target tumours whilst the positron emitting samarium-142 allows accurate dosimetry. In another example from the life sciences, an ISOLDE experiment is studying how bacterial proteins break down toxic mercury salts into non-toxic elemental mercury.

Louvain-la-Neuve's Jules Deutsch discussed how ISOLDE investigates questions more traditionally associated with particle physics. When it comes to fundamental interactions, said Deutsch, ISOLDE and particle physics complement each other closely. By studying correlations between the electron and the neutrino in argon-32 beta decay, one ISOLDE experiment has searched for anomalous couplings which may indicate the interplay of exotic particles such as leptoquarks or scalar bosons. Preliminary results agree with the Standard Model. Another Standard Model check performed at ISOLDE concerns parity violation. In the Standard Model, parity violation is complete in charged current interactions: there are no right-handed charged weak couplings. If right-handed W bosons exist, their masses must be far greater than the familiar left-handed W. Consequently they must have frozen out soon after the Big Bang, leaving today's predominantly left-handed weak interactions. Any evidence for incomplete parity violation in charged current interactions could probe the timescale at which this freeze-out occurred.

High energy accelerators systematically search for additional gauge bosons, some of which might couple to right-handed fermions. But the mass reach of these searches is

In R&D work at the Japanese KEK Laboratories for future electron-positron linear colliders, the first high-power C-band klystron developed by KEK and Toshiba generated 50 MW peak power at a frequency of 5712 MHz. The compact klystron is 1.2 m high.

The stable and clean waveform of the output power from the klystron is very promising for industrial radiofrequency C-band applications, as well as for a linear collider for physics.

limited by the energy of the machine. A new ISOLDE experiment studying the polarization of positrons emitted from fluorine-17 relative to the nucleus will be sensitive to right-handed W masses up to 400 GeV if the right-handed W has coupling strengths similar to its left-handed counterpart. Otherwise, the experiment will provide constraints on right-handed W couplings complementary to those provided by high energy collider experiments.

The final word went to Achim Richter, ISOLDE Committee Chairman, who found it astonishing "that so much remarkable research has been performed in an area of just 50 x 20 metres". Richter took the opportunity to discuss the role of ISOLDE within the increasing number of radioactive beam facilities around the world. He underlined the complementarity of ISOLDE type beams with those from high energy fragmentation reactions available for example at Germany's GSI laboratory. His conclusion was that strong collaboration in the field is vital, and looked forward to a future for ISOLDE every bit as varied as the past.

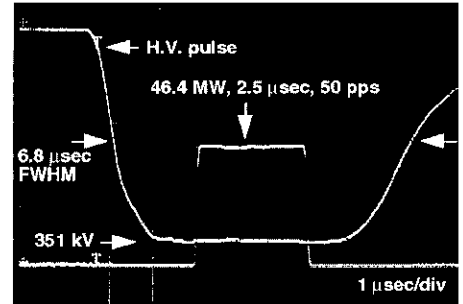
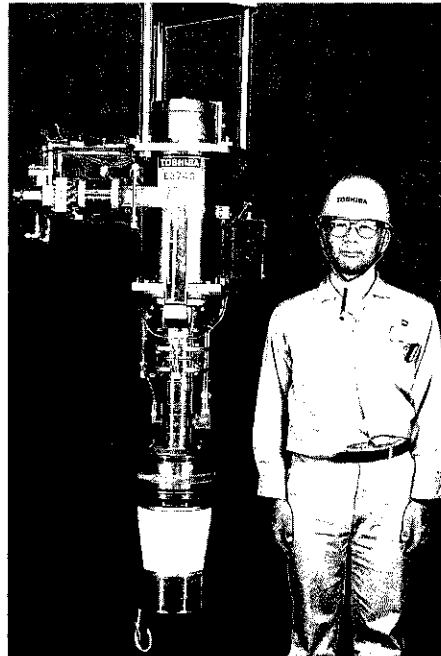

High voltage pulse and rf output

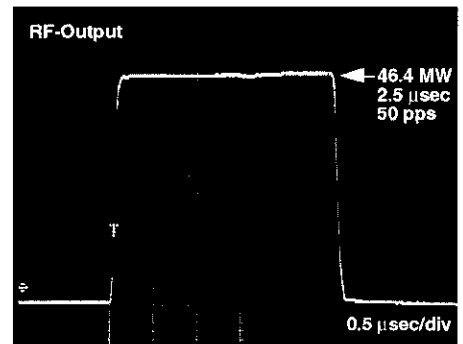

RF output power

the energy range beyond that currently attainable by LEP at CERN, and up to the TeV region.

The design goal of the klystron for the 500 GeV version of the linear collider is 50 MW peak output power with 2.5 microsec pulse width and 50 % power efficiency, and the first klystron demonstrated excellent performances, close to the final goal.

The C-band R&D project started in 1996, aiming to establish the radiofrequency (RF) technologies required to accelerate beams with a field gradient of 32 MV/m or higher along the main linac. Waveguide components, the klystron modulator and a new RF-pulse compressor have been developed.

The shunt impedance of a normal conducting RF-cavity scales as the square root of the drive RF frequency. This is why the X-band (11 GHz) or even higher frequencies are chosen in linear collider designs. Generally speaking, however, higher frequency RF systems require higher

technologies, especially when the fabrication of the accelerating structures demand high precision machining. Extensive R&D programmes push these technologies at several major laboratories around the world.

For the C-band frequency (5.7 GHz), between the conventional S-band (3 GHz) and the ambitious X-band, both the shunt impedance and the system performance are intermediate. Scientists at KEK strongly believe that the C-band system can be built by today's existing technologies or at most some modest R&D effort to overcome relatively minor problems.

Since KEK is pioneering C-band high-power RF for beam acceleration, custom-made components, such as high-power waveguides, were not available at the outset. As the first step, waveguide components were de-

KEK C-band klystron achieves 50 MW

The first high-power C-band klystron developed by the Japanese KEK Laboratories and Toshiba successfully generated 50 MW peak power at a frequency of 5712 MHz. This is a part of the R&D being carried out at KEK for future electron-positron linear colliders in

A new experiment at Brookhaven measures the anomalous magnetic moment of the muon with unprecedented precision.

signed and developed from scratch in 1996. Then the first C-band klystron was developed and 50 MW achieved in 1997.

This success was possible thanks to excellent teamwork between KEK and industry. CERN collaborated with KEK to develop a 'smart' modulator. KEK scientists developed the basic design using various computer simulations to optimize performance, while engineers and technicians from industry with their well experienced and established skills built the klystron. KEK scientists are very satisfied with the results, and confident in their C-band RF-system design.

R&D work now focuses on further improvement in the power efficiency and on cost reduction with a view towards future mass production.

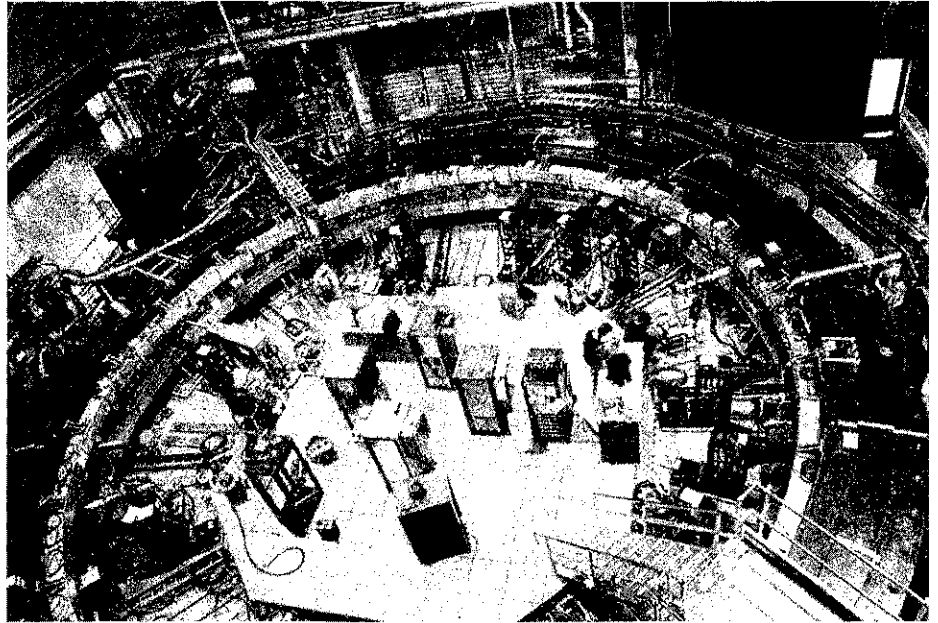

DESY 200 MW from S-band klystron

In January an S-band (3 GHz) klystron at the DESY Laboratory in Hamburg attained more than 200 MW with a pulse width of 1 microsec. This klystron, built in SLAC (Stanford), is the result of a collaboration between DESY, SLAC, Philips and Darmstadt's Technische Hochschule as part of DESY's linear electron-positron collider research and development effort using S-band technology. This S-band route was de-emphasized last year in favour of the superconducting TESLA approach (July 1997, page 1).

BROOKHAVEN Muon magnetism sub- parts per million

As well as providing a valuable further test of the underlying theory, a new experiment at Brookhaven measuring the magnetic moment of the muon with unprecedented precision could unearth signs of new physics.

A spinning charged particle acts as a tiny magnet, and this magnetism is measured by its g-value, defined as the ratio of magnetic moment to angular momentum in appropriate units. For an ideal (Dirac) particle $g=2$. The discovery in an atomic beam magnetic resonance experiment in 1947 that the electron g-value is slightly larger (2×1.00116), together with the simultaneous discovery of the Lamb shift in hydrogen, led to the creation of modern quantum electrodynamics (QED) with its renormalization

scheme to remove infinities from the calculations.

The precise measurement and theoretical calculation of the electron anomalous g-value agree to a precision of about 20 parts per billion (ppb), underlining the power of pure QED.

In many instances, the muon resembles a heavy cousin of the electron. A series of famous experiments at CERN from the early 1960s to 1980 measured the muon anomalous g-value with ever increasing precision, finally achieving a precision of 7.2 parts per million [1]. Since the muon is 207 times heavier than the electron, in addition to the usual electromagnetic radiative contributions the theoretical calculation also includes a small radiative contribution from heavier, strongly interacting particles. This was measured with about 10% accuracy in the last CERN experiment, and the result agrees with the theoretical value, confirming the idea of the muon as a heavy electron and establishing the

Powered Crates

Further to all our CERN approved CERN-Spec. Crates NIM-, CAMAC-, FAST BUS-, VXI- and VMEbus Wes-Crates supplies other Crates based upon these Systems.

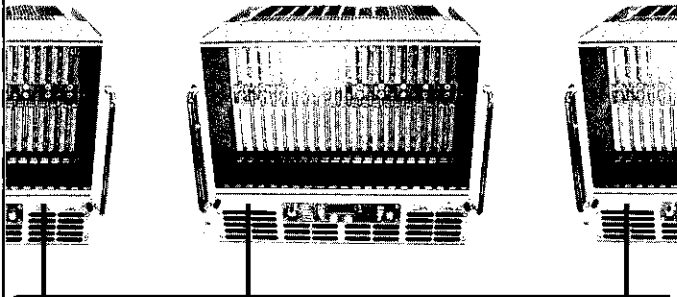

CAN remote control

ISO Layer 7: CANtrol® user defined CAL

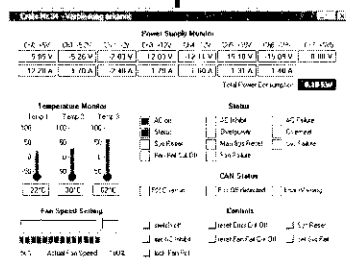

- 160 pin J1/J2
- opt. 95 pin J0 (2 mm)
- +3.3V/48V
- more user def. I/O-pins
- slot geographical address
- EMC
- ESD
- injection / extraction handle
- slot keying
- rear I/O transition boards
- fast 2 edge protocol
- ...and more features

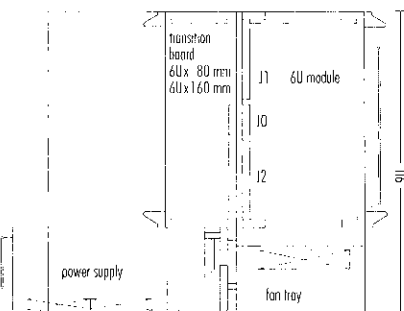

VME 64 Extension Compliance

Every CERN-Spec. so far has given rise to a CERN-approved Crate from:

Crates and Power Supplies from WES-Crates are flexible because of modular systems.

WES-Crates

Wes-Crates GmbH
Pattburger Bogen 33
D-24955 Harrislee/Flensburg
Germany
Telefon 0461 - 77 41 77
Telefax 0461 - 77 41 41
International +49 461
E-mail: sales@wes-crates.de



Zertifiziert nach
ISO 9001
Germanischer Lloyd
Certification

Your contact in Geneva: HiTech Systems Sa, Avenue Wendt 16, 1203 Geneva, Tel.: 022/3447788, Fax: 022/456551
Your contact at PSI and ETH Zürich: Dipl.-Ing. Kramert AG, Villigerstr. 370, CH-5236 Remigen, Tel.: 056/2841555, Fax: 2845055



ESONE
European Studies on
Norms for Electronics



SysComms '98

25-26 March '98. CERN, Geneva, Switzerland

EXHIBITION AND TECHNICAL CONFERENCE

INCORPORATING THE ESONE EMBEDDED SYSTEMS WORKSHOP AND THE VITA EUROPE CONFERENCE

Organised by ESONE in collaboration with ESOFTEA Europe, GroupIPC, PICMG Europe and VITA Europe, SysComms '98 features top speakers from research and industry. It covers all aspects of embedded and real-time systems including data acquisition, process control, software and hardware architectures, bus systems and communications.

PAPERS INCLUDE:

- VMEbus standardisation - VME64x and VME64xP
- The Read-Out Crate in the ATLAS DAQ/EF prototype I
- The ALICE DATE: the benefits of using hardware and software industry standards in a real-time environment
- Ethernet in HEP Data Acquisition and Triggering
- Use of Programmable Logical Controllers at CERN - Present situation and future trends
- Application deployment - Thomas Jefferson National Accelerator facility
- CANbus for industrial-controls applications in a high-energy physics experiment
- Studies of SCI for the ATLAS level-2 trigger system

PLUS MANY MORE!! - See Web Site for full details.

4 GOOD REASONS FOR VISITING SYSCOMMS

- Education
- Discover the "State of the Art"
- Meet the key Suppliers
- Get to know CERN

... plus

- * Full Companion Programme
- * Conference Dinner
- * Guided tours of CERN

Free entry to pre-registered bona fide CERN and ESONE personnel: Register via the Web at

<http://www.cern.ch/ESONE/Syscomms98/>

or find out more by e-mail to:
syscomms@cern.ch

OR

lyndseyc@gghnet.demon.co.uk

The SysComms '98 Conference and Exhibition is organised with the kind permission of CERN management.

The muon spin precession is reflected in the yield of positrons emerging from muon decay.

radiative contribution due to strongly interacting particles.

Some 12 years ago a new experiment with much higher precision was proposed at Brookhaven [2] with the goal of measuring the muon magnetism to 0.35 ppm, a factor of 20 improvement over the CERN value. (Two members of the CERN experiment - Francis Farley and Frank Krienen - are active in the current new Brookhaven experiment.)

With this precision the 1.3 ppm contribution due to the weak interaction from virtual processes involving the Z and W carrier bosons should be observed and would provide a sensitive test of renormalization in electroweak theory. In addition, it will be a sensitive and powerful test for unexpected contributions, especially for muon and W substructure or anomalous couplings, but also for supersymmetry and leptoquarks, or indeed for almost any proposed modification of the Standard Model - in several cases at a sensitivity beyond that provided by present or planned high energy colliders [3].

The basic principle of the Brookhaven experiment is the same as that of the last CERN experiment and utilizes the violation of parity (left-right symmetry) in the decays of positive pions into positive muons, producing polarized muons. In the subsequent parity violating decay of a positive muon into a positron and two neutrinos, the muon spin direction is determined from its correlation with the direction of the emergent positron. The experiment involves a measurement of the difference (ω_a) between the spin precession frequency and the orbital frequency of a muon in the homogeneous magnetic field of a storage ring.

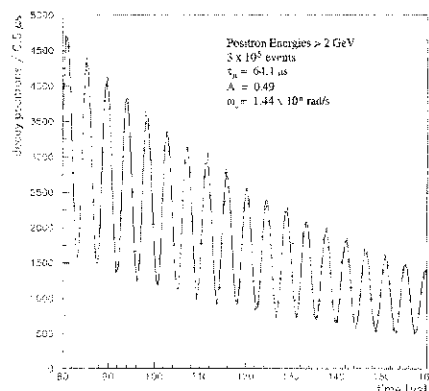

The principal new features which should make possible a much improved precision include:

- A factor of 100 or more higher proton beam intensity in the Brookhaven Alternating Gradient Synchrotron (AGS) compared to that used at CERN. (The dominant error in the CERN experiment was statistical).
- A superferric C-magnet type storage ring of high homogeneity and stability together with a powerful NMR magnetic field measurement system to make possible absolute field determination to 0.1 ppm.
- A detector system based on lead-scintillating fibre electron calorimeters with associated waveform digitizers and a 400 MHz frequency standard measuring time intervals to 20 ps over an interval of about 200 microsec.
- In addition to pion injection, there is provision for direct muon injection into the storage ring, with a fast kicker to put the muons on orbit. Direct muon injection will significantly increase the number of stored muons while at the same time reducing the detector-paralyzing flash accompanying pion injection.

Other new features include a superconducting inflector for bringing the pion or muon beam into the

storage region through the yoke of the storage ring, a traceback chamber for positron trajectories to provide information on the stored muons, and position sensitive detectors based on scintillating paddles at the front of several electron calorimeters.

Experimental checkout and initial data-taking at the AGS took place from April to July 1997, using pion injection. All the principal features of the experiment operated successfully, with the approximate characteristics expected, including the AGS, its pion beamline, the superconducting inflector, the storage ring with its electric quadrupole focusing elements, the NMR magnetic field measuring system and the detectors with their time interval measuring system.

Storage of positive muons from positive pion decays in the ring was observed with the small muon capture efficiency calculated. A large background 'flash' signal was seen in the detectors soon after injection due to positive pions which produce a large neutron background. The fast rotation structure of the muon beam with the cyclotron period of 149 ns has been observed from the time spectrum of the positron decays.

The figure shows the exponential muon decay following injection time, modulated by the precession frequency ω_a for the time interval from 80 to 180 microsec after pion injection into the storage ring. Analysis of all the data obtained is in an advanced stage. Some 20×10^6 positrons with energies greater than 1.3 GeV have been detected, corresponding to a statistical precision of about 10^{-5} , comparable to that achieved at CERN. Systematic errors are expected to be smaller than the statistical error, and are being studied.

Giorgio Matthiae (Rome), a pioneer of 'Roman pot' detectors to approach as near as possible to circulating beams, introduces a recent International Symposium on Near Beam Physics at Fermilab.

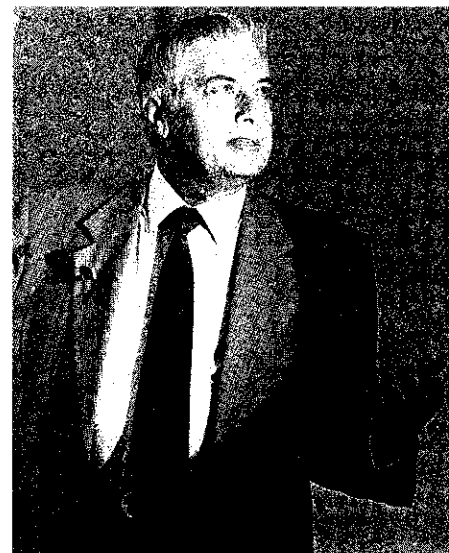

of Technology described plans for B physics at Fermilab where a similar possibility is being discussed. Other new proposals seek to investigate the diffractive region in more detail.

Beam dynamics issues were covered by Todd Satogata (Brookhaven), Pat Colestock (Fermilab), Weiren Chou (Fermilab), and Walter Scandale (CERN). While much progress has been made, nonlinearities and the difficulty of halo characterization hinder practical understanding.

Some of the best information on beam halo is provided by experimental and theoretical work on collimation. Collimation studies were reported by Bernard Jeanneret (CERN), Mike Sullivan (SLAC), and Stan Pruss and Sasha Drozhdin of Fermilab. Mike Church described the collimation system planned for the Tevatron.

At Brookhaven's RHIC with its heavy ion beams some of the beam dynamics and collimation issues will be particularly intriguing. Dejan Trbojevic described the collimation considerations for the machine while Sebastian White reported on the

A major run of the experiment is planned for July 1998 to February 1999 with several months of parasitic beam and about two months of dedicated beam. Direct muon injection will be employed using a fast muon kicker to store muons in the ring. In addition, many improvements will be made, based on experience from the initial 1997 run. There appear to be no obstacles to achieving the target precision of 0.35 ppm.

*The g-2 collaboration
(Brookhaven, Boston, Cornell, Fairfield, Illinois, Lawrence Berkeley Lab, Max Planck Inst., Minnesota, Budker Inst., KEK, RIKEN, Science U of Tokyo, Yale)*

References

- 1 - J. Bailey et. al., *Nucl. Phys. B150 (1979) 1*; F.J.M. Farley and E. Picasso in *Quantum Electrodynamics*, ed. T. Kinoshita, World Scientific, Singapore (1990) 479.
- 2 - BNL AGS E821, *Design Report, 3rd Edition (1995)*.
- 3 - T. Kinoshita and W.J. Marciano *ibid.* 419.

WORKSHOP Near the beam

Getting the most out of expensively produced particle collisions calls for a lot of gymnastics in beam handling and experimental techniques. In particular, the intercept those particles swept along by the beam means getting as near to the beam as possible without actually disturbing it.

A recent International Symposium on Near Beam Physics held at Fermilab surveyed the current

understanding of beam halo phenomena, accelerator techniques, and diffractive physics and other experiments that operate near beams, with the emphasis on the interplay of these topics rather than experimental results. The symposium also appraised future possibilities, looking to see where additional work would be useful.

Giving the introductory presentation was Giorgio Matthiae (Rome), a pioneer in the development of the 'Roman pot', one of the first devices to run near circulating beams. Developments in this area now span three decades. Roman pots are still being used as adjuncts to powerful collider detectors to study hard diffraction processes in which particles emerge close to the beam direction. Another pioneering "in-beam" technique, that of gas targets and jets, was reviewed by Mario Macri (Genoa). The first gas target to operate was in E36, which was also the first experiment to operate at Fermilab.

A wide range of diffractive physics can be attacked with these techniques. Johannes Ranft of Siegen described a number of interesting issues. Mike Albrow of Fermilab reported on the recent addition of Roman pots to the Tevatron CDF detector. Andrew Brandt (Fermilab) described the proposed addition of Roman pots to the companion D0 experiment.

Carsten Hast, Klaus Ehret and Michael Bieler reported on the status of HERA-B at DESY that exploits a wire target placed near the proton beam in DESY's HERA electron-proton collider. Bieler also discussed the HERA proton collimation and beam diagnostic systems and gave an overview of the Roman pot forward spectrometers in operation at HERA. Dan Kaplan of Illinois Institute

development of a new zero degree neutron calorimeter for luminosity monitoring that might also have applications at CERN's LHC.

Operating near an accelerator beam poses several challenges. Mechanical stability is important. Vasily Parkhomchuk of Novosibirsk and Craig Moore of Fermilab outlined some of the experience with vibration problems. Hisayasu Mitsui (Toshiba) summarized work at the Japanese KEK Laboratory with Ken Takayama investigating radiation damage to near beam components. Alan Hahn and Vladimir Shiltzev of Fermilab discussed instrumentation for beam monitoring.

By its nature, extraction requires operating near the accelerator beam. One of the interesting new extraction developments is the use of bent channeling crystals. Alexey Asseev reviewed extraction work at IHEP (Protvino) including their pioneering work on crystal extraction, Konrad Elsener covered the very detailed studies of crystal extraction at CERN and Thornton Murphy summarized a recent 900 GeV Fermilab extraction experiment where luminosity-driven extraction was recently achieved. Valery Biryukov of IHEP reported on theoretical investigations, noting that the efficiency can be modelled quite well.

Walter Scandale (CERN), Cyrus Taylor (Case-Western Reserve), and Nikolai Mokhov (Fermilab) closed the symposium with reviews of several broad questions, listing some of the principal requirements of experiments - halo free beams, stable orbits, luminosity measurements accurate to 2-3%, and good collimation to cut the background.

Perhaps the ultimate criterion of nearness to the beam is the distance of a device from the beam in units of

beam size. A survey showed just how close some devices operate: crystals and wire targets are positioned at 3.5 to 9 beam radii away from the beam axis, primary collimators at 5.5 to 8, and Roman pots at 8 to 15.

Update information on the Symposium is available on the World Wide web at <http://www-ap.fnal.gov/NEARBEAM/>. The Symposium was sponsored by Fermilab with particular support from the Beams Division and its head, Dave Finley. Additional help was received from KEK.

From Dick Carrigan and Nikolai Mokhov

PROTVINO Efficient crystal extraction

The efficiency of using the crystal channeling technique to steer and deflect particle beams by means of bent crystals has greatly improved in recent years.

Another step in this direction has been made at the Russian Institute for High Energy Physics, Protvino, where a very short (7 mm along the beam direction) silicon crystal with a 1.75 mrad bend was used to extract a fairly powerful beam of 70 GeV protons from the synchrotron.

The intensity of the channeled beam was up to 2×10^{11} per spill of 1.1 s duration. The tiny crystal was working in this regime for about 24 hours delivering some 10^{11} protons every 9 s (the machine cycle). The crystal had an estimated temperature of several hundred degrees C but retained the same high channeling efficiency.

The crystal efficiency (defined as

The Russian Institute for High Energy Physics, Protvino, has used a very short (7 mm along the beam direction) silicon crystal with a 1.75 mrad bend to extract a fairly powerful beam of 70 GeV protons from the synchrotron. The solid points show the prediction from the recent Near Beam Physics Workshop at Fermilab (see previous story) and the open circles the subsequent measurements.

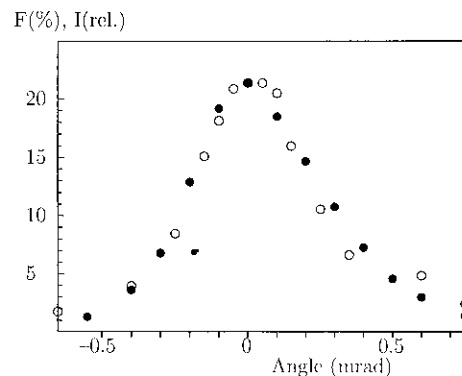

the ratio of extracted beam to all other beam loss) was measured to be about 20%, much higher than the typical 0.01% efficiency of crystal extraction routinely run at IHEP since 1989. The measured efficiency and angular scan are in good agreement with simulation predictions.

The efficiencies in the three major crystal extraction experiments (at CERN's SPS, Fermilab's Tevatron, and IHEP) look now comparable. One important difference is that the divergence of the beam circulating in the IHEP accelerator was 10 times greater than Lindhard angle (critical angle for channeling), so only a few percent of the beam particles satisfied the channeling criteria.

The efficiency was boosted due to an increased number of proton encounters with a radically shortened crystal ("multipass" extraction). The theory had predicted that increasing the "multiplicity" factor in extraction by shortening the crystal in this way would greatly improve the efficiency, and the new results are the first proof of this prediction.

The theory, now checked in all the major experiments in a 14 - 900 GeV energy range, predicts a 70-90% efficiency for a crystal with optimal length in the crystal extraction and collimation projects at TeV range accelerators.

Hunting down the quark-gluon plasma

For the past several years physicists have been eagerly searching for hadron meltdown into quark-gluon matter (QGP) in high-energy nucleus-nucleus collisions: the miniature 'Little Bang' replicas of the Big Bang. Last December some 350 physicists gathered in Tsukuba, Japan, for the Quark Matter '97 conference to review what is presently known in this research field. The reported experimental data span an energy range from 1 to 200 GeV per nucleon, coming from the SIS, AGS and SPS synchrotrons (respectively at GSI Darmstadt, Brookhaven and CERN).

The resemblance of the Little Bangs of high energy nuclear collisions to the cosmological Big Bang is not accidental. In both cases detailed observations of a late stage in the evolution of the system reveal the physics of the early dense state. The strong expansion (the 'Bang') prevents both systems from being globally balanced at all times, some traces of their early history being thereby preserved.

The expansion pattern, the first link to the past, has been studied in both fields through different manifestations of the Doppler effect. For both the light emitted by receding galaxies and the hadrons emerging from the decoupling fireball created in a nuclear collision, the energy spectra are shifted according to the (local) expansion velocities relative to the observer. The transverse expansion in the Little Bang is directed towards the detectors and the measured particle momentum spectra are therefore blue-shifted, rather than red-shifted as in cosmology. At QM'97 several groups presented impressive evidence for this blue shift, the systematic flattening of the transverse mass spectra with increasing rest mass of the hadron,

from pions to deuterons.

The extraction of the transverse expansion velocity is ambiguous since a similar effect results from thermal motion, the temperature of the decaying source being in principle unknown. Fortunately, quantum statistical (Bose-Einstein) correlations of identical pions effectively experience a red shift, providing the missing constraint. Indeed, these correlations take place within the particle source which expands like the Early Universe. These complementary observations define the 'true' freezeout temperature, T , approximately 120 MeV, and the 'true' transverse expansion velocity, around 0.55 of that of light, as reported for lead-lead collisions by the NA49 Collaboration at CERN (Figure 1).

This violent expansion is an expected manifestation of high energy density and pressure in an early evolution stage. Theoretical models without collective expansion before the hadrons are formed fail to

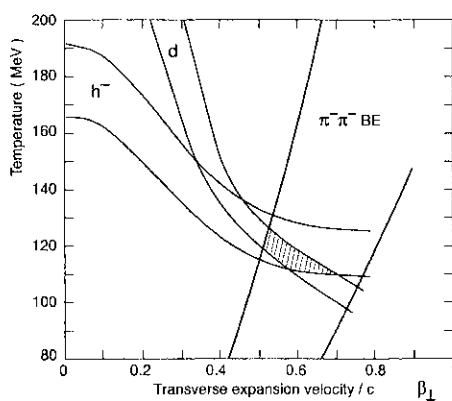
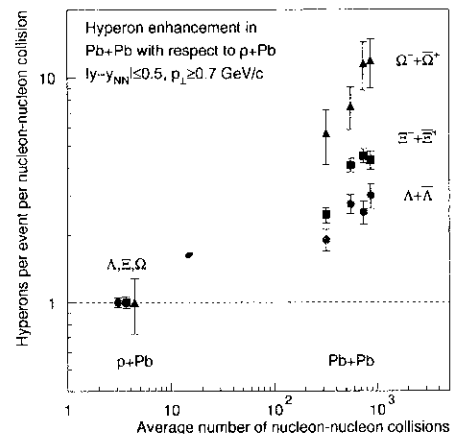

Figure 1: Little Bang physics: The combinations of temperature and expansion velocity compatible with the measured spectra of negative particles (h^-), deuterons (d) and Bose-Einstein correlations intersect at a common origin with T approx 120 MeV and an expansion velocity about 0.55 that of light. Such expansion is the result of initial high energy density and pressure.

Figure 2: More evidence of new behaviour. The number of multi-strange hyperons produced per event and per elementary nucleon-nucleon collision shows a spectacular increase (a factor of 10 for the omega) from proton-lead to lead-lead collisions.



reproduce such a fast transverse growth, giving an exciting clue that we might no longer be dealing with normal hadronic matter.

The character of the system at an early evolution stage may be further understood through the study of its 'chemistry' - the relative abundance of particles with different quantum numbers. For a rough global picture of strangeness production it is sufficient to look at the total lambda and kaon yields, which carry away most of the produced strange quarks. Comparing their sum to the total number of produced pions (a measure of the entropy created in the collision) provides a quantitative basis for the discussion of enhanced strangeness production in heavy ion collisions.

At SPS energies, in both sulphur-sulphur and lead-lead collisions, this strangeness fraction is about twice that in nucleon-nucleon collisions, in agreement with the expectations for the phase transition into QGP. It seems that whatever mechanism causes the global strangeness enhancement, it is already fully effective in sulphur collisions at 200 GeV per incident nucleon and does not require the larger reaction volume of lead-lead collisions.

The yields of multi-strange



Laboratoire d'Anncy-le- vieux de **P**hysique des **P**articules

The LAPP, french laboratory of IN2P3 (Institut National de Physique Nucléaire et de Physique des Particules) is looking for

a Software Engineer

Mission: Within the Computing Division, he/she will be involved in the development and implementation of projects in experimental particle physics and will join research groups composed of physicists and engineers. He/she will estimate the required computing facilities and participate in the specification and design of engineering systems or software-based products involved in data analysis.

Requirements: Graduate Software Engineer with good knowledge of UNIX environments, Client-Server technology, C and C++ including background in networking (TCP services, AFS file system...). Qualifications in object-oriented technologies are necessary: design (UML), database (Objectivity). Capabilities in software engineering methods (such as RG00040, PSS-05...) and tools (Rational...) will be strongly appreciated.

An initial contract (CDD) limited to 18 months is proposed. The successful candidate will then be eligible for a position of 'Ingénieur de Recherche' (CNRS). Application letter including a curriculum vitae should be sent to the following address:

L.A.P.P.- Service du Personnel
B.P. 110
74941 Annecy le Vieux Cedex - France

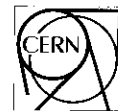
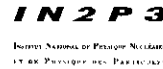

CERN European Laboratory for Particle Physics

CERN is the world's largest laboratory for scientific research. With 19 Member States, it is used by elementary particle physics researchers from all countries.

Visits on request
tel. 0041 22 767 8484

Microcosm exhibition,
Monday-Saturday from 9.00 to 17.00 hr,
entry free

Route de Meyrin (bus 9 CERN)

Plastic Scintillators

■ High counting efficiency
 ■ Excellent light transmission
 are properties of our plastic scintillators.
 Different shapes are available
 from 0.25 mm thick
 with dimensions up to 500 x 500 mm.
 All pieces can be machined to a highly
 polished surface or provided with
 special coatings, including
 inorganic scintillators.

ZANSSER ANALYTIC

Howarth Road, Maidenhead, Berks SL6 1AP
 Phone ++44 (0) 1628 773202, Fax ++44 (0) 1628 672199

What is used the World over ?

From Hyogo Prefecture* to Alameda County**,
 passing by the Hanseatic City***

DESY
 Berkeley**
 Spring-8*

Modular Parametric Current Transformer

To measure DC Beam Current...

- On sources or linacs, industrial cyclotrons or implanters
 - On circulating machines: boosters, storage rings
- It measures the beam current with $<10\mu\text{A}$ rms resolution
 9 full scale ranges from $\pm 10\text{mA}$ to $\pm 5\text{A}$. Analog out $\pm 5\text{V}$

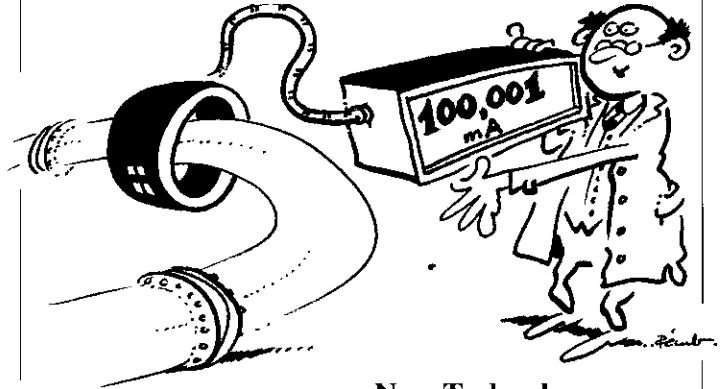

Precision Beam Instrumentation

New Technology
 Lower Price



Europe: Bergoz Tel.: +33-50.41.00.89
 U.S.A.: GMW Tel.: (415) 802-8292
 Japan: Repic Tel.: (03) 3918-5326

Advertisements in CERN COURIER

Format A4

Monthly publication

All advertisements are published in both English and French editions. Second language versions accepted without extra charge.

Space (page)	Actual size (mm) width by height	Cost per insertion (Swiss Francs)			
		1 insertion	3 insertions	5 insertions	10 insertions
1/1	185 x 265	2200	2100	2000	1900
1/2	185 x 130	1300	1200	1100	1020
1/4	90 x 265 90 x 130	750	700	650	600

These prices include no entitlement to special placing.

Supplement for:

-one additional colour 1500 SwF

-1/2 page 800 SwF

-Covers:

Covers 2 and 3 (one colour) 2200 SwF

Cover 4 (one colour) 2700 SwF

Publication date 1st of month of cover date

Closing date for

positive films and copy 1st of month preceding cover date

The cost of making films and of translation for advertisements are charged in addition.

Screen offset 60l/cm (150 English)

Advertisements cancelled after 1st of month preceding cover date will be invoiced.

These rates are effective for the year 1998

Inquiries for Europe:

Micheline FALCIOLA / CERN COURIER - CERN

CH - 1211 Genève 23 Suisse

Telephone: 022/767 41 03

Telefax: 022/782 19 06

Inquiries for the rest of the world:

please see page III



Since 1967

BUSINESS & TRAVEL CAREERS

PROFESSIONAL TRAINING

- INTERNATIONAL SECRETARIES
- SECRETARY-HOSTESSES
- TRAVEL- AND TICKET AGENTS

English & French Sections

Sessions of 10 or 20 months - Details on request

ACADÉMIE DE LANGUES ET DE COMMERCE

8, rue Winkelried - 1201 Geneva - Tel. 41 22 / 731 77 56

Switzerland

Formations professionnelles :

Les métiers du
**Commerce International
 et du Tourisme**

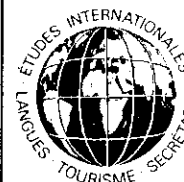

Ecole fondée
 en 1967

- Assistant(e)s de Direction
- Secrétaires - Hôtesse
- Agent(e)s de Voyages
- Langues • Informatique

Programme sur demande



Membre de l'AGEP et de la
 Fédération suisse des écoles privées



ACADEMIE DE LANGUES ET DE COMMERCE

8, rue Winkelried - 1201 Genève - Tel. 022 / 731 77 56

Fax 022 / 731 28 85

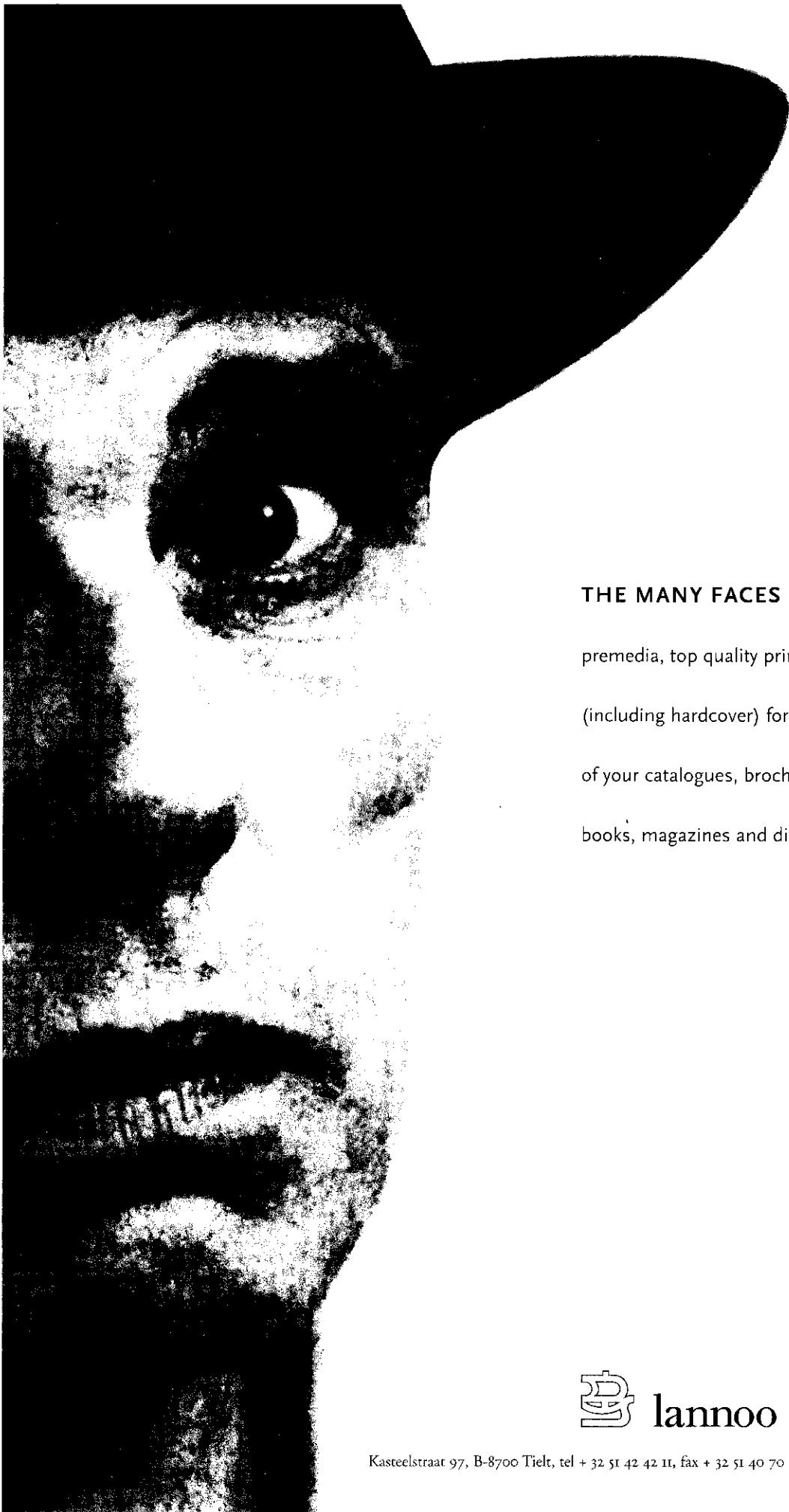

THE MANY FACES OF PRINTING

premedia, top quality printing and finishing
(including hardcover) for the production
of your catalogues, brochures, annual reports,
books, magazines and diaries

 **lannoo**

Kasteelstraat 97, B-8700 Tielt, tel + 32 51 42 42 11, fax + 32 51 40 70 70, lannoo@lannooprint.be

Blei by

SCHERRER

Als Branchenführer sind wir Ihr kompetenter Lieferpartner für Bleigussteile, Bleigranulat, Walzblei, Bleibausteine und Bleiplatten. In jeder Form als Strahlenschutz und Abschirmung. Gerne erwarten wir Ihre Anfrage.

Jakob Scherrer Söhne AG
Allmendstrasse 7
8059 Zürich 2
Telefon 01 202 79 80
Telefax 01 202 79 90

sicovend

le point de départ pour l'électronique

**Haute précision
pour votre progrès!**



Sicovend SA vous offre la **résistance haute précision** que vous cherchez, soit sous forme SMD ou conventionnelle, soit en réseau de résistances. La performance répond à la norme MIL-R-55182/9.

Contactez-nous pour de plus amples informations et vous verrez que le progrès sera aussi bien en votre

Sicovend AG, CH-8304 Wallisellen, tél. 01 830 31 61, fax 01 830 61 96
<http://www.sicovend.ch> E-Mail info@sicovend.ch

A unique advertising medium for scientific and technical equipment

CERN COURIER is the internationally recognized news magazine of high energy physics. Distributed to all the major Laboratories of the world active in this dynamic field of fundamental research, it is compulsive reading for scientists, engineers, administrators, information media and buyers. Written in simple language and published simultaneously in English and French it has become the natural communication medium for particle physicists in Europe, the USA, Russia, Japan – everywhere where the fundamental nature of matter is studied.

Published from CERN, Switzerland, it also has correspondents in the Laboratories of Argonne, Berkeley, Brookhaven, Cornell, Fermi, Los Alamos and Stanford in the USA, Darmstadt, DESY and Karlsruhe in Germany, Orsay and Saclay in France, Frascati in Italy, Rutherford in the U.K., PSI in Switzerland, Serpukhov, Dubna and Novosibirsk in Russia, KEK in Japan, TRIUMF in Canada and Beijing in China.

The annual expenditure on high energy physics in Europe is about 1800 million Swiss francs. The expenditure in the USA is about \$ 1100 million; There is also considerable expenditure in Russia.

CERN COURIER is the way into all high energy physics research Laboratories. If you have a market in this field, there is no surer way to make your products known than by advertising in CERN COURIER.

All enquiries to:

Europe

Advertising Manager
Micheline Falcicola
CERN COURIER
CERN
CH-1211 GENEVA 23
Tel. 41 (022) 767 41 03
Telex 419 000 CER
Telefax 41 (022) 782 19 06

Rest of the world

Guy Griffiths
Advertising Manager, USA
Gordon and Breach Publishers
820 Town Center Drive
LANGHORNE PA 19047
Tel.: (215) 750-2642
Fax: (215) 750-6343

MULTI HV CONNECTORS

22 OR 51 MINIATURE 3kV DC CONTACTS

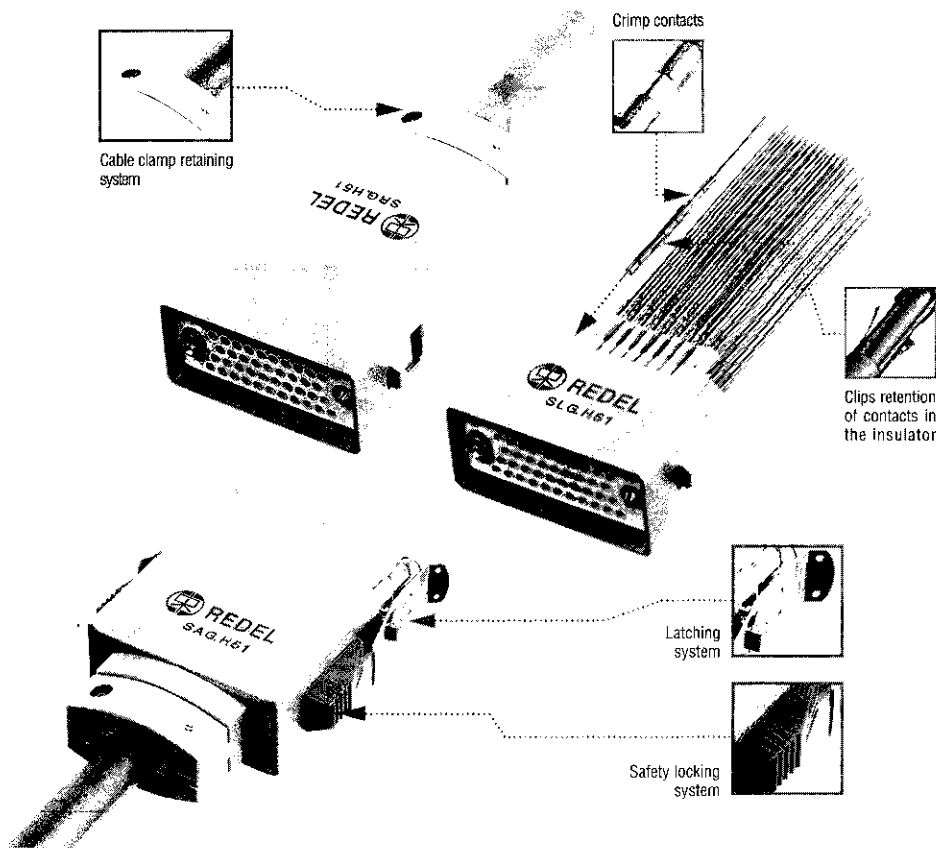

The new REDEL K & S series, using new miniature HV 3kV DC contacts, have been specially developed to meet the requirements of applications requiring high packing density in a compact design.

TECHNICAL CHARACTERISTICS

- High packing density (22 or 51 contacts)
- Miniature HV 3kV DC contacts for crimping and clips retention in the insulator
- Gold-plated contacts according to MIL-G-45204C type I, class 1
- Latching with safety locking
- Cable clamp retaining system for cable diameters 1 to 3.3 mm

LEMO SA
P.O. Box 194
CH-1024 Ecublens (Switzerland)
Tel: (+41 21) 691 16 16
Fax: (+41 21) 691 16 26
<http://www.lemo.ch>

UNE HAUTE IDÉE DE L'ENTREPRISE

À 10 minutes de l'aéroport international de Genève, au carrefour des réseaux autoroutiers F/CH/D/I, près de deux gares TGV, à proximité du prestigieux CERN.

propose sur 40 hectares :
des parcelles de terrains viabilisées (achats ou location)
des bureaux et des bâtiments mixtes
une pépinière d'entreprises
des services spécifiques d'assistance aux entreprises pour une implantation régionale et pour des relations avec le CERN
un Bureau de Rapprochement des Entreprises agréé par la CEE.

LE TECHNOPARC - PAYS DE GEX -

proposes 100 acres (40 ha) of equipped site with :
pieces of land (purchasing or renting)
offices spaces
activity buildings
incubator
Business Corporation Center agreed by CEE.

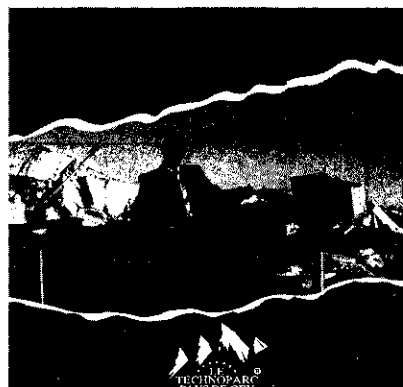

CONTACT:
SYNDICAT INTERCOMMUNAL D'ACTIVITÉ DU PAYS DE GEX
50, rue G. Eiffel - BP 104
F-01632 Saint-Genis-Pouilly
Tél. (033) 04 50 42 20 00 - Fax (033) 04 50 42 20 20
E-mail: bregex@leman.com
internet: <http://www.leman.com/~bregex>

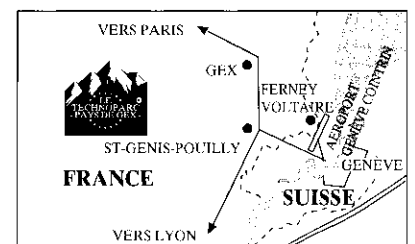
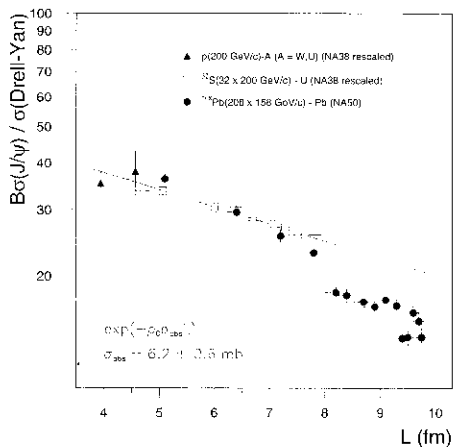

Figure 5: Most suggestive of QGP formation is this strong suppression of the J/ψ yield, relative to the normal production pattern, observed in lead-lead collisions above a certain 'violence'. The variable L represents the length of nuclear matter expected to be crossed by the J/ψ mesons.



'anomalous' J/ψ behaviour of the central collisions and the normal behaviour of the peripheral points, which follow the trend of the lighter systems. The production of Drell-Yan dileptons, on the other hand, evolves from peripheral to central lead-lead collisions according to the theoretical expectations, lending further support for the unconventional nature of this J/ψ suppression.

Rescattering with hadronic co-movers (produced pions) cannot simultaneously explain the "anomalous" suppression in central lead-lead collisions and the "normal" absorption in peripheral lead-lead and lighter systems. QGP-based suppression scenarios seem to be in a much better position to describe all the available J/ψ data.

Contrary to the J/ψ , the ψ' charmonium state is already strongly suppressed in sulphur-induced collisions, and this pattern continues smoothly in ever more central lead-lead collisions. While the suppression of this loosely bound charmonium state can easily be explained by scattering with conventional hadronic co-movers, it can also be due to melting in the QGP medium right at the transition to deconfinement. The

melting of the more strongly bound J/ψ resonance requires a somewhat higher temperature and considerably larger energy density, likely to be attained only in the centre of the most violent lead-lead collisions.

The simplest common explanation for all these features appears to be that, at the present SPS energies, a quark-gluon plasma is created in the early stages of the heavy-ion collisions. After these exciting results, made possible by the dedicated gold and lead beam programmes at the AGS and SPS, the participants left the meeting with well-founded enthusiasm, feeling that a major breakthrough has just been made in our hunt for the QGP. Researchers eagerly look forward to consolidating this new insight with more data and with increased theoretical understanding.

By Daniel Ferenc, Ulrich Heinz and Carlos Lourenço



Co-chairmen of the organizing committee of the 13th International Conference on Ultra-Relativistic Nucleus-Nucleus Collisions, held at the University of Tsukuba, Japan, were Kohsuke Yagi (left) and Shoji Nagamiya. The meeting was sponsored by the Yamada Science Foundation.

Physics monitor

MIDDLE EAST More bridges

A recent seminar in Italy consolidated the valuable initial contact between Israeli and Arab physicists made at Dahab, Sinai, in November 1995 (January 1996 issue, page 21).

With science delimited only by the frontier of understanding, the quest to understand more about the world around us overcomes political barriers. Basic physics has acted as a useful catalyst in establishing international contacts in difficult areas.

Initiated by the same Steering Committee for International Collaboration in the Middle East which masterminded the Dahab meeting, a seminar on experimental techniques in high-energy and synchrotron radiation physics, held in the Villa Gualino, near Turin, last November attracted 31 participants, including 10 Israelis, 6 Jordanians, 2 Moroccans, 9 Palestinians and 1 Syrian. They heard presentations by world class scientists, including Nobel Prizewinners Carlo Rubbia and Jack Steinberger,

As well as the formal lectures, a stimulating panel discussion led to a number of concrete proposals, including a call for improved internet connections and for a special website, and for funding to support international collaboration in the region.

Israeli physicists offered to provide two fellowships for young Palestinian researchers to participate in the work of Israeli research groups at CERN and at DESY, Hamburg.

Another idea was for a European synchrotron radiation source, such as

A seminar on experimental techniques in high-energy and synchrotron radiation physics, held near Turin last November brought together Israeli, Jordanian, Moroccan, Palestinian and Syrian science students. This photograph was taken during an excursion to the nearby historic mediaeval monastery of Novalesa.



BESSY I in Berlin, once it becomes locally obsolete, could be considered for refurbishment and removal to a Middle East site.

These proposals will be discussed in a three-day meeting of the Planning Committee for International Collaboration in the Middle East in Sweden in April, which will also decide the venue for the next seminar in the series.

The Turin meeting was financed by local authorities through the Institute for Scientific Interchange Foundation (ISI), by the Swedish Institute through Uppsala University, by the International Centre for Theoretical Physics, Trieste, and by UNESCO. The organizing committee was chaired by Tord Ekelof of CERN and Uppsala.

Minister at the Swedish Permanent Mission in Geneva J. Söderberg said 'Scientific cooperation across geographic and cultural borders helps stimulate not only the advancement of ideas in the professional field, but also the build-

ing of bridges and the establishment of contacts on the personal and human level.'

Physics and detectors for a linear electron-positron collider

ECFA - the European Committee for Future Accelerators - is organizing a second joint study with DESY on Physics and Detectors for a Linear Electron-Positron Collider. The first study, in 1996-7, prepared an outline Conceptual Design Report for a Linear Collider experiment and reported upon its considerable physics potential; especially for Higgs boson physics, for searching for supersymmetric particles and for high precision measurements of the properties of the top quark and of the electroweak gauge bosons.

The results were incorporated in a two-volume report (ECFA 1997-182; DESY 1997-048) which includes two alternative designs for the linear collider; the superconducting TESLA machine and a normally conducting S-Band design.

(The plans include facilities for other branches of science which would utilize the linac technology, including nuclear physics and the development and use of free electron lasers producing high quality synchrotron radiation down to the X-ray region.)

The new study has two main goals: i) to complete the physics studies begun in 1996, using better models of the detector; ii) to investigate the potential - and the problems - of operating the Linear Collider and the detector at ten times the previously assumed luminosity; i.e. 5×10^{34} per cm^2 per s at 500 GeV collision energy, and at correspondingly higher luminosities at higher energy.

Results of the physics studies will be submitted to the International Linear Collider Workshop at Sitges, near Barcelona, in the Spring of 1999 (the next in the "LCWS" series - following Saariselka, Finland, 1991; Waikoloa, Hawaii, 1993; Morioka, Japan, 1995), when there will be an opportunity to compare with the plans from the USA and Japan.

The eventual aim of the study is to produce in the year 2000 a costed Technical Design Report for the Collider and its detector with a complete physics case. The study begins in Spring 1998 (see <http://www.desy.de/conferences/ecfa-desy-lc98.html> for details of the first workshop).

There will be three or four workshops during 1998 at a number of European venues. Topics to be covered include machine-detector interface, backgrounds, triggering, physics goals, generators, detector

Projects to help developing countries was the focus of a recent meeting of scientists at CERN for the 14th Annual General Meeting of the World Laboratory, which supports many such projects around the planet, including the 'Kangaroo Mother' method of helping underweight babies by keeping them next to the skin of their parents.

simulation, detector performance in specific physics analyses and detector R&D. All interested should look at the website and come to the first workshop.

The organizing committee is David Miller (UC London, chair), Enrique Fernandez (Barcelona, ECFA chair), Michael Danilov (ITEP), Rolf Heuer (CERN), Leif Jonsson (Lund), Paolo Laurelli (Frascati), Martin Leenen (DESY), Francois Richard (Orsay), Ron Settles (Munich), Torbjorn Sjostrand (Lund), Albrecht Wagner (DESY) and Peter Zerwas (DESY).

World scientists meet in CERN

The progress of projects to help developing countries was the focus of a meeting of an unusually varied group of scientists at CERN over the weekend 20-22 November for the 14th Annual General Meeting of the World Laboratory, which supports many such projects around the planet. The meeting also provided the setting for the award of the Gian Carlo Wick Medal to Gerard 't Hooft, for his fundamental work in theoretical physics.

Roberto Gallo, of the Institute of Human Virology in Maryland, flew in from Nigeria, where he and Guy De They are helping an HIV project. He gave a general world survey of AIDS then described the research work and help they are giving. Another World Laboratory AIDS project in Uganda was presented by Gaetano Giraldo of Florence.

Georges Charpak of CERN introduced the 'Kangaroo Mother' method of helping underweight

babies by keeping them next to the skin of their parents. The leader of the project is Nathalie Charpak-Hernandez, based in Bogota. The treatment also includes giving instruction in childcare, and results in fewer deaths, bigger babies and higher IQs. Under the auspices of the World laboratory, groups applying this approach have now started in Vietnam and Ethiopia as well as in Latin America.

Carlo Lerici of Bologna has been working to improve fruit and vegetable production in China: some million trees are now virus-free with 99.8% survival, and 23 factories produce 20,000 tons a year of orange and carrot juice.

Giovanni Levi of Genoa is leading a project to develop advanced biotechnology in China. It has developed a transgenic tomato whose leaves, but not the fruit, are poisonous to bugs. There is also progress with virus-resistant potatoes and maize. Lucio Parenzan of Bergamo is helping with heart diseases in Kenya and Uganda.

Tsung-Dao Lee of Columbia has been guiding the Centre of Advanced Science and Technology in China, whose members published 317 papers in the last year, largely in the Physical Review, Physical Review Letters and Physics Letters.

Michael Graetzel of the EPFL in Lausanne is developing, together with Chinese and Australian groups, photovoltaic cells using titanium dioxide in nanocrystalline form. The lower efficiency in producing electricity is more than compensated by its low cost and the fact that diffuse light can be used. Kai Siegbahn of Uppsala has been helping in material science using electron spectroscopy in China.

A summary of this and other work in a total of 26 research centres in 11



countries and 55 projects in 20 scientific fields was given by World Laboratory President Antonino Zichichi, who coordinates its valuable efforts together with its General Secretary, Claude Manoli, and central staff based in Lausanne.

John Ellis and Douglas Morrison

Feynman in New Zealand

QED - The Strange Theory of Light and Matter, was the title of a popular book by Richard Feynman first published by Princeton University Press in 1985. Feynman makes passing reference to the fact that the book is based on a series of general lectures on QED which were first delivered in New Zealand.

Feynman had doubts about the

Low And High Voltage Power Supplies

High Voltage Plug-in Units

DC Power Supplies

for research, electronics and industry.

Special Power Supplies for super conducting coils, plasma equipments, electromedicine, electron beam equipments, electronic microscopes, as well as capacitor charging power supplies, sources for electronic tubes and more.

20 Years

fug

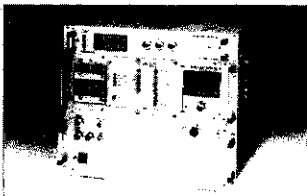

Please ask for our Main Catalogue '98

We deliver more than 650 standard models, more than 100 models are available ex stock!

F.u.G. Elektronik GmbH

Florianstr. 2 ; D-83024 Rosenheim ; GERMANY

Tel.: ..49(0)8031 2851-0 ; Fax: ..49(0)8031 81099

eMail: fug-elektronik@t-online.de ; Internet: http://www.fug-elektronik.de



<http://www.ntp.org.uk>

Journals:

Radiation Protection Dosimetry

The International Journal of Radioactive Materials Transport
Applied Health Physics Abstracts and Notes

Books, monographs and conference proceedings:

Accidents and emergency planning
Instrumentation and measurements
Medical diagnostic radiology
Environmental radiation and radon
Non-ionising radiation
Radiation dosimetry (general)
Radiation dosimetry (microdosimetry)
Radiation dosimetry (neutrons)
Radiation dosimetry (solid state)
Radiation protection
Radiobiology and radiation risks
Transport of radioactive materials.

Nuclear Technology Publishing
P.O. Box 7, Ashford
Kent TN23 1YW, England

Telephone (44) (1233) 641683 Facsimile (44) (1233) 610021
E-mail: Sales@ntp.org.uk Subscriptions@ntp.org.uk

High voltage
. High precision
.. High quality
... Low price

HV-sources in

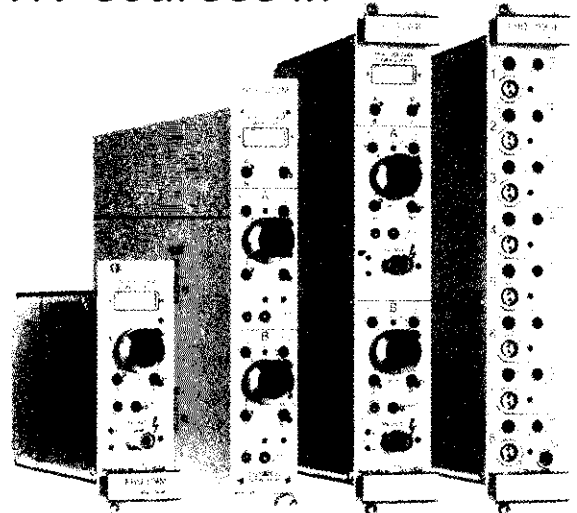

NIM, CAMAC, VME & CAN

- including instruments with 100 pA / 10 mV resolution
- Ripple < 2 mV_{p-p} , Stability < 5 * 10⁻⁵
- cost effective Multi-channel systems of any configurable size

HV-sources for Special Applications

- PMT base integrated HV-supplies, e.g. PHQ 2020 for Philips XP2020



- Detector mounted HV-supplies

iseg

Ingenieurbüro Spezialelektronik Gleisberg

STRUCK

Dr. Bernd Struck, Baeckerberg 6, D-22889 Tangstedt
Phone: + + 49 (0) 4109 55-0, Fax: + + 49 (0) 4109 55-133
E-mail: sales@struck.de, http://www.struck.de

Bookshelf

accessibility of lectures on QED to a general audience, and initially chose not to deliver these lectures at his native Caltech. Rather, he chose New Zealand as his testing ground, giving the New Zealand physics community the dubious honour of being the guinea-pigs for these lectures.

They were delivered in 1979 as the Sir Douglas Robb lectures at the University of Auckland. Although the book is an excellent self-contained description of QED, watching an unedited Feynman reveals his style and enthusiasm for his subject in a way which is impossible in print. Some of Feynman's examples and descriptions in these lectures, even though not as refined as in the published version, provide fascinating insight into both the material of QED and into Feynman's character.

They are on four VHS video tapes available in NTSC Format from tot@lafn.org Friends of Tuva, Belvedere, CA 94920

or in PAL Format from bqedtapes@phy.auckland.ac.nz

Dr. John Dudley P.O. Box 182, Physics Department, Auckland University, Private Bag 92019, Auckland, New Zealand

Also available from Friends of Tuva is a memorable video of Feynman giving the 1986 Dirac Memorial Lecture on 'The Reason for Antiparticles' (see November 1997, page 28).

The Rise of the Standard Model - Particle Physics in the 1960s and 1970s, Edited by Lillian Hoddeson, Laurie Brown, Michael Riordan and Max Dresden, Cambridge University Press, ISBN 0 521 57082 4 (hbk) 0 521 57816 7 (pbk)

The Rise of the Standard Model - Particle Physics in the 1960s and 1970s - was the title of a seminar held at SLAC, Stanford, in June 1992, featuring many distinguished speakers who have made major contributions to the Standard Model edifice. Although the proceedings have only just been published, over the intervening five-year period the Standard Model has remained unchallenged, so fortunately, the value of the book has in no way diminished.

The Standard Model of basic physics takes the six quarks found in Nature and groups them into three pairs - up/down, strange/charm and beauty/top, with each pair assigned a lepton (electron, muon, tau) and an associated neutrino. These three quark/lepton families all interact via the electroweak force, while the quarks interact among themselves through the strong 'colour' force.

In the 1960s, the exploitation of particle symmetries and the discovery of the quark model laid the foundations of the Standard Model.



David Gross - 'Field theory was in disgrace.'

To understand and interpret these new ideas, a host of diligent field theorists strove to understand the forces at work between quarks, searched for a synthesis of electromagnetic and weak interactions, and attacked the underlying problem of renormalization, for only when renormalization was assured could field theory calculations be done confidently.

Despite heroic efforts, by the end of that experimentally fruitful decade the research spotlight had turned away from field theory. As David Gross says in his contribution, 'Field theory was in disgrace; S-matrix theory was in full bloom.'

However the early 1970s soon saw this rectified. Renormalization was shown to be OK, and, after years adrift, innovative ideas of spontaneous symmetry breaking suddenly found themselves on firm ground. Almost at the same time, the subtle properties of 'Non-Abelian' field theory (when the order in which the operators are placed is significant - AB does not produce the same outcome as BA) showed how a gentle close-range inter-quark force becomes a virtually unbreakable bond as the distance between the quarks increases. The paradox of quarks is that although they roam around relatively freely deep inside protons and neutrons, they cannot be prised out of their subnuclear prisons.

Soon after these theoretical breakthroughs came the 1973 discovery of neutral currents at CERN, underlining the electroweak synthesis of electromagnetic and weak interactions, and the 1974 'November revolution' discovery of the J/psi at Brookhaven and SLAC and its interpretation in terms of a fourth quark, charm. Later in the

decade came the discovery of particles from the third quark/lepton family, an experiment using polarized beams at SLAC (Stanford) which revealed more about the structure of electroweak effects, and evidence for the gluon carriers of the inter-quark force at DESY. Underlying these experimental advances were the development of particle colliders and their attendant instrumentation, and of new beams, such as those of neutrinos.

By the end of the 1970s, betting against the Standard Model dried up, but it nevertheless remained to uncover the heavy W and Z particles which carry the weak force (accomplished at CERN in 1983) and to find the sixth - 'top' - quark (at Fermilab in 1994-5). These final Standard Model landmarks are outside the time frame of the Stanford meeting, which was confined to the 60s and 70s. Nevertheless the book provides a valuable compendium of Standard Model history, with first-hand accounts of milestone discoveries and breakthroughs, and of development work, all rich in detail, opinion and anecdote. It is not possible to list all the 38 contributions, and dangerous to select just a few.

The chronology of experimental discoveries is clear. Less apparent is the crucial role played by the underlying theory. As Steven Weinberg declares in his contribution 'Changing Attitudes and the Standard Model' - 'The rise of the Standard Model was accompanied by profound changes in our attitudes toward symmetries and towards field theory.'

These profound changes did not happen overnight. Silvan Schweber says in his perspective, 'The formulation of the Standard Model is one of the great achievements of the

human intellect... It will be remembered - together with general relativity, quantum mechanics, and the unravelling of the genetic code - as one of the outstanding intellectual advances of the 20th century. But much more so than general relativity and quantum mechanics, it is the product of a communal effort.' This the book clearly shows, in dogged perseverance and in inspired breakthroughs in theoretical understanding, in the tireless development and construction of new facilities, and in diligent experiment.

GF

Bruno Pontecorvo, Selected Scientific Works, Recollections of B. Pontecorvo, Società Italiana di Fisica, ISBN 88 7794 115 4

The centenary of the Italian Physical Society is marked by this volume to honour the memory of Bruno Pontecorvo (1913-93), an Italian physicist who went on to gain worldwide fame. Pontecorvo's suggestions led to many advances, particularly in neutrino physics. Many of the landmark papers are included in the book, including the idea of experiments with neutrino beams, on the distinction between different types of neutrinos, and on the possibility of neutrino masses and oscillations. Also included are descriptions of his early nuclear physics work in Rome and Paris. These papers are complemented by contributions from physics notables including N. Cabibbo, V. Dzhelepov, L. Lederman, L. Okun and J. Steinberger.

A limited number of copies, normally \$45 (Lit 70000), are available at the special price of \$30 (Lit 50000) from Società Italiana di

Fisica, Il Nuovo Cimento, Via Castiglione 101, 40136 Bologna, Italy fax +39 51 581340, <http://www.sif.it>

Image and Logic - A Material Culture of Microphysics, by Peter Galison, University of Chicago Press, ISBN 0 226 27916 2 (hbk) 0 226 27917 0 (pbk)

This immense scholarly work (950 pages) covers the evolution of particle physics detectors and associated instrumentation during the 20th century. Having painstakingly sifted through a mountain of source material, the author has compiled a rich compendium of recent science history. Galison is Mallinckrodt Professor of the History of Science and of Physics at Harvard and came to particle physics prominence with his analysis of the 1973 saga of the discovery of the neutral currents, finally published in his 1987 book 'How Experiments End'.

His new book traces the changing face of particle physics detector technology, particularly the shift from cloud and bubble chambers, recording visible tracks, to electronic instruments working with digital track information.

Innovative technology supplants the outdated as remorselessly as new generations succeed their parents: new detectors for old. However Galison prefers to construct elaborate metaphors:

'.....two subcultures of instrumentation formed a wordless creole: On one side is the image tradition of photographic practices aiming at noninterventionist objectivity - producing homomorphic representations of nature. On the other side is the logic tradition of electronic practices aiming at manipulative persuasion - producing

homologous representations of nature. Out of the two, I will argue historically, sociologically and philosophically, came a wordless pidgin that evolved into a wordless creole....'

Thus inflated, the sheer size of the book is thwarting.

Particle Physics and the Schrödinger Equation, by Harald Grosse and André Martin, Cambridge Monographs on Particle Physics, Nuclear Physics and Cosmology, ISBN 0 521 39225 X (hbk) £35 (US\$54.95)

The venerable Schrödinger equation, first written down in 1925, enabled quantum mechanics to analyse energy levels in atomic and molecular structure. The trick was to get the right potential and to solve the resultant differential equations. However for a long time, the equation was confined to atomic and molecular problems.

Despite the success of the simple quark model in the late 1960s, few people thought of treating particles as quark 'atoms'. However the 1974 discovery of the J/psi showed that, for heavy quarks such as charm, the concept of a tightly bound quark-antiquark system could be extremely fruitful. The trick now, just as in the 1920s, is to get the potential right. This thorough book displays how our understanding of the spectra and decays of particles containing heavy quarks has benefited.

Introductory Nuclear Physics, by P.E. Hodgson, E. Gadioli and E. Gadioli Erba, Oxford University Press, ISBN 0 19 851989 3 (hbk), 0 19 851897 8 (pbk)

A comprehensive introduction to nuclear structure and nuclear reactions. This textbook introduces the concepts and historical development of the subject, whilst conveying the questions preoccupying researchers today.

The book gives a full definition of the particles that make up the nucleus, the nuclear forces that govern them and the different models of nuclear structure. Alongside, are explanations of the experimental techniques in use today, including the principles of modern particle accelerators and detectors. In a final section, the authors introduce the applications of their research to nuclear astrophysics and nuclear reactors.

The book is primarily intended as a textbook for undergraduate and graduate students, however it should also be useful as an up-to-date reference source for those working in the field. Each chapter is accompanied by a set of problems.

Books received

Bose-Einstein Correlations in Particle and Nuclear Physics, by Richard M. Weiner, Wiley, ISBN 0 471 96979 6

A collection of 47 reprints, with comments and an introduction, of papers published from 1960-1995.

Hot Electrons in Semiconductors - Physics and Devices, edited by N. Balkan, Oxford Science Publications, ISBN 0 19 850058 0

A collection of 21 authoritative contributions.

The Beginner's Guide to Mathematica Version 3, by Jerry Glynn and Theodore W. Gray, Cambridge University Press, ISBN 0 521 62202 6 £50/\$64.95 (hbk) 0 521 62734 6 £16.95/\$24.95 (pbk)

A tutorial and a reference book covering an important area.

Energy Stabilization of Electrostatic Accelerators, J. Takács, Wiley ISBN 0 471 97039 5

About the 'Cinderellas' of the accelerator world.

Particle Accelerators

http://www.gbhap.com/Particle_Accelerators/

Executive Editor

Eberhard Keil, CERN, CH-1211, Geneva 23, Switzerland • E-mail: eberhard.keil@cern.ch

Particle Accelerators provides a much-needed channel of communication for those involved in the research on, and the design, construction and operation of particle accelerators. The journal publishes original articles on a variety of topics in theoretical and experimental accelerator physics, and in accelerator technology. Topics in accelerator physics include particle-orbit theory, collective effects, impedances and wakefields, analytical and computational techniques, as well as new accelerator concepts. Topics in accelerator technology include magnet design, the engineering of radio-frequency and vacuum systems, pulsed and dc high-voltage techniques, applications of cryogenics and superconductivity to accelerators, accelerator instrumentation and shielding, beam transport, and applications of accelerators.

Abstracted/Indexed in:

ISI Current Contents – Physical, Chemical & Earth Sciences / SciSearch / Research Alert (USA)

ISSN: 0031-2460 • 4 issues per volume • Current Subscription: Volume 61-62 (1998)

For further information, or a FREE sample copy, please contact:

North/South America: IPD, PO Box 32160, Newark, NJ 07102, USA • Tel: +1 (800) 545 8398 • Fax: +1 (215) 750 6343

Europe/Middle East/Africa: IPD Marketing Services Ltd., PO Box 310, St. Helier, Jersey, JE4 0TH, Channel Islands

Tel: +44 (0) 118 956 0080 • Fax: +44 (0) 118 956 8211

E-mail: info@gbhap.com • Visit Our Home Page: <http://www.gbhap.com>



Gordon and Breach Science Publishers

A member of The Gordon and Breach Publishing Group



EUROPEAN SYNCHROTRON RADIATION FACILITY INSTALLATION EUROPEENNE DE RAYONNEMENT SYNCHROTRON

In Grenoble, France, the ESRF has constructed a state-of-the-art storage ring for 6 GeV electrons operated 24 hrs/day as a high brilliance synchrotron radiation source in the field of X-rays. Financing of the ESRF is shared by twelve European countries. In 1998, 30 ESRF beamlines will be open to the users. The ESRF thus supports scientists in the implementation of fundamental and applied research on the structure of condensed matter in fields such as:

Physics, Chemistry, Crystallography, Earth Science, Biology and Medicine, Surface and Materials Science.

The Technical Services Division is in charge of general support functions such as mechanics, vacuum, alignment, buildings and infrastructure. The Survey and Alignment Group is now seeking to recruit:

The Head of the Survey and Alignment group (m/f) (ref. 6103)

The candidate must be a chartered Engineer from a recognised Topography/Geodesy Engineering School. He/she will be in charge of a group of one Engineer and seven Technicians all experts in the field of Microgeodesy techniques. The group is in charge of aligning the Synchrotron Radiation Source components and the Beamlines Equipment with a very high level of precision and surveying the evolution of their relative position. In addition to a very high level of professional experience, excellent managerial qualities are required from the Head of the Group.

The Buildings and Infrastructure Group is seeking to recruit an

Engineer (m/f) (ref. 6106)

The successful applicant will be a chartered engineer with five years experience in an industrial or scientific environment, with a sound knowledge (both theoretical and practical) of: Heating, ventilation, air conditioning; Fluids; Regulation, servo controls, centralised management; Maintenance.

The working language at the ESRF is English, knowledge of French is an asset.

The ESRF offers an exciting opportunity in an international atmosphere, sharing a site with several other major European scientific institutes. New staff coming from outside the Grenoble area benefit from installation allowances, and non-French staff also benefit from an expatriation allowance in accordance with specific regulations.

If you are interested, please send us a fax (+33 (0)4 76 88 24 60) or an e-mail (brink@esrf.fr) with your address, and we will provide you with an application form. You can also print out an application form on the World Wide Web <http://www.esrf.fr>.

Deadline for returning the application forms: 15 April 1998.

We are also recruiting: scientists, post-docs, PhD thesis students, engineers and technicians. If you are interested consult our vacant positions on the World Wide Web (<http://www.esrf.fr>).

ESRF * Personnel Service * Ref. 6103 or Ref. 6106 * BP220 * F-38043 GRENOBLE Cedex 09 * FRANCE

People and things

Peter Jenni - Swiss Greinacher Prize



Eminent physicist Masatoshi Koshiba (seated, second from right) received the most prestigious prize in Japan, the Order of Cultural Merit, from the Emperor on 3 November. The other distinguished recipients were (left to right): organic chemist Teruaki Mukaiyama; Soushitsu Sen, Head of the Urasenke School tea cult; lacqueur ware authority Setsuro Takahashi; environmental economist Hirofumi Uzawa.



On people

One of the first two recipients of the prestigious Swiss Greinacher Prize, awarded in Bern on 6 February, was Peter Jenni of CERN for his outstanding contributions to the experimental study of fundamental quark and gluon interactions in high energy proton-antiproton collisions (as a key member of the UA2 collaboration) and for his initiative and leading role in the planning and construction of the ATLAS experiment for CERN's LHC collider. The other recipient of the prize was Jürg Beer of EAWAG Zurich.

Raymond Stora of LAPP, Annecy, receives the prestigious Max Planck Medal of the German Physical Society at its Spring Meeting in Regensburg on 25 March "In recognition of his important contributions to

quantum field theory (analytical properties of amplitudes, differential geometry and topological aspects of gauge theory). The BRS (Becchi - Rouet - Stora) transformation introduced in 1975 plays a central role today in quantum chromodynamics and the standard model."

APS awards

The 36 American Physical Society Prizes and Awards attributed for 1998 include several in particle physics and related fields.

John Bahcall of Princeton's Institute for Advanced Study receives the Hans Bethe award for his fundamental work on the solar neutrino problem and nuclear astrophysics.

Joel M. Moss of Los Alamos

receives the Tom W. Bonner Prize for his work on dimuon production in proton-nucleus interactions.

Nathan Seiberg and Edward Witten of Princeton's Institute for Advanced Study receive the Dannie Heinemann Prize for their decisive advances in elucidating the dynamics of strongly coupled supersymmetric field and string theories.

Henry Kendall of MIT receives the Nicholson Medal for his important role in creating and leading the Union of Concerned Scientists.

David Nygren of Berkeley receives the Panofsky Prize for the development of the Time Projection Chamber.

Leonard Susskind of Stanford receives the J.J. Sakurai Prize for his pioneering contributions to hadronic string models and field theory.

Matthew Sands of Santa Cruz receives the Robert R. Wilson Prize for his contributions to accelerator physics.

Reg Richardson (1912-1997)

Shigeki Suwa (1920 - 97)

Order of Cultural Merit

The most prestigious prize in Japan, the Order of Cultural Merit, has been awarded to prominent physicist Masatoshi Koshiha for his pioneering work in neutrino astronomy, particularly for the pioneer observation of the neutrino burst from the 1987a supernova in February 1987 with the Kamiokande detector. The prize was awarded by the Emperor himself at the Imperial Palace on 3 November, Japan's Cultural Day.

The observation and measurement of these supernova neutrinos shed new light on the massive explosions which mark the death of large stars. In addition, the same Kamiokande detector showed that protons do not decay at the rate predicted by the simplest grand unified theory.

Koshiha's neutrino telescope has led to the SuperKamiokande detector, about a factor of about ten larger, and which is addressing the crucial question of particle physics and cosmology, the mass of neutrino. It is now presenting decisive data on solar and atmospheric neutrinos, and will give an answer to the oscillation issue through the long baseline experiment using neutrinos from the KEK synchrotron in Tsukuba, 250 km away.



Raised in Edmonton and Vancouver, Reg moved to California at the age of 12 and later attended UC Berkeley, taking his PhD under Ernest Lawrence. After war work on calutrons at Berkeley, in 1946 he led a small group converting the fixed-frequency 37-inch cyclotron to a synchrocyclotron, demonstrating Veksler and McMillan's concept of phase stability a few months before Goward's first demonstration of synchrotron operation.

After taking up a faculty appointment at UCLA, he retained his connection with Berkeley and, in an attempt to overcome the intensity limitations of pulsed machines, built the first sector-focused cyclotron there in 1950 and where electrons reached a relativistic beta of 0.5. Back at UCLA he led the construction of a 50 MeV cyclotron, taking advantage of Kerst's spiral sector focusing and Rickey's negative hydrogen ion acceleration concepts

to provide clean beam extraction at variable energy. This was completed in 1962 and resulted in a strong graduate school in nuclear physics.

His 1963 proposal for 750 MeV cyclotron "meson factory" - a term he coined - was unsuccessful at UCLA, but adopted in Canada in a downsized version, making possible the construction of the 520 MeV 200 microamp TRIUMF cyclotron - over whose construction and commissioning Reg presided as the second director (1971-6).

In supposed retirement, he initiated the drive for the TRIUMF KAON Factory, and - always out ahead - was already working on the 100 GeV extension before the ink was dry on the 30 GeV proposal! Throughout his career he continued to participate in nuclear and particle physics experiments, notably that which introduced the Kurie plot for determining beta-decay energies, and the first measurement of the

Reg Richardson (1912-1997)

J. Reginald Richardson of Berkeley, UCLA and TRIUMF, responsible for the first experimental demonstration of phase stability, the first synchrocyclotron, and the first sector-focused cyclotron, died in California on November 25, aged 85.

lifetime of the charged pion. His greatest legacy, however, must be the more than 200 sector-focused cyclotrons now in operation around the world, whose intense beams have had a major impact on nuclear and particle physics, condensed matter physics, chemistry and medicine. Reg was awarded the Wilson Prize of the American Physical Society in 1991.

Shigeki Suwa (1920 - 97)

Shigeki Suwa, founding director of the Japanese KEK Laboratory, died on December 16, aged 77. After studying nuclear theory at Tokyo, Professor Suwa subsequently moved into the experimental field, initially measuring hyperfine structure and the magnetic moment of nuclei. When Tokyo's Institute of Nuclear Study (INS) was established and construction of the 160 cm cyclotron launched, he joined the team in 1953, taking responsibility for the radiofrequency system and inventing the efficient "n=1 extraction" scheme. In 1960 Suwa was invited to Minnesota for a project to accelerate polarized protons in a linac. After its successful completion, he began research in asymmetry measurements in polarized proton and nucleus scattering. Then he was invited to join the construction of by Argonne's Zero Gradient Synchrotron (ZGS) and the development of a polarized proton target. Using one of his best polarized targets, Suwa's work on hadron spectroscopy became a role model for the field.

When the Japanese high energy community began preparations for its first proton synchrotron, he was called back to INS to lead the project. After a long period of negotiation with

government and much technical R&D, as the head of the project he pushed the scheme through and KEK was established in 1971 with its 12 GeV proton synchrotron as major facility. The natural appointment as the new laboratory's first director, he oversaw the project during the entire construction period of the first KEK accelerator.

After deciding to retire as laboratory director in 1977, at the request of his successor, Tetsuji Nishikawa, he remained at KEK as physics department head, guiding the physics programme at the new accelerator.

His leadership was not confined to particle physics. In 1980 he was appointed director of the new PARMS Particle Radiation Medical Science Center of the University of Tsukuba, utilizing protons from the 12 GeV synchrotron's booster. With the new centre on the right track, he moved to the Science University of Tokyo in 1984 and devoted himself for many years to the education of young students.

With unwavering resolution, Professor Suwa was one of the guiding lights who lifted the Japanese high energy physics community from obscurity following World War II to its present world position. Much as his diligent and persevering work was appreciated by his colleagues and students, his noble and unselfish spirit will be even more sorely missed.

Werner Hardt 1923 - 98

Friends and colleagues mourn Werner Hardt's death which deprives the accelerator community of a truly great personality. Of his numerous creative contributions to accelerator physics many will continue to bear his name.



Werner came to CERN in 1964, having just completed the design and construction of the magnets for the DESY synchrotron. One of his early inventions was the "Hardt Nose", which extends the good field region of a magnet. At CERN he led the design of the Booster for the European 300 GeV machine (which finally became the SPS). Based on the insight that an accelerator's space-charge limit does not depend on the circumference (the so-called "Hardt Puzzle"), he conceived multiple-ring accelerator schemes, amongst them one of three interlaced rings dubbed "Hardt's TART" It was he who advocated adding to the PS a multiple-ring Booster, rather than a 200 MeV linac, thus laying the foundation for the evolution to today's PS record intensities.

When the PS was to become the injector for the SPS, Werner joined the PS Division in 1970, where he remained until his retirement in 1988.

Dutch NIKHEF Laboratory Director Ger van Middelkoop - innovative national funding.



He extended his interest beyond injector aspects, e.g. to the crossing of transition energy and to slow extraction. An invaluable contribution was his design of the gamma-transition jump, which opened the way for the PS (and then the Brookhaven AGS and others) to unprecedented intensities. He elaborated the ultra-slow extraction for LEAR, where observing the "Hardt Condition" and applying "Hardt's Chimney" permitted ejecting continuous spills over several hours instead of seconds.

Werner was a venerated teacher and discussion partner who combined mathematical ingenuity with technical realism. Many of us learned our accelerator physics from him, and after hours at the blackboard in his smoke-filled room

The signing at SLAC, Stanford, of the latest agreement between the United States and the Peoples Republic of China on cooperation in high-energy physics, by Peter Rosen (right) and Zhou Guangzhao, with many representatives of both communities.

Visiting CERN on 19 January was Helmut Stahl, Secretary of State of the German Federal Ministry of Science, Education, Research and Technology (centre) seen here admiring prototype magnets for CERN's LHC proton collider with new President of CERN Council Hans Eschelbacher (right) and German delegate to CERN Council Arno Freytag. In the background is Dietrich Güsewell, Head of CERN's EST (Engineering Support and Technologies) Division.

(Photo CERN HI 98.1.014)

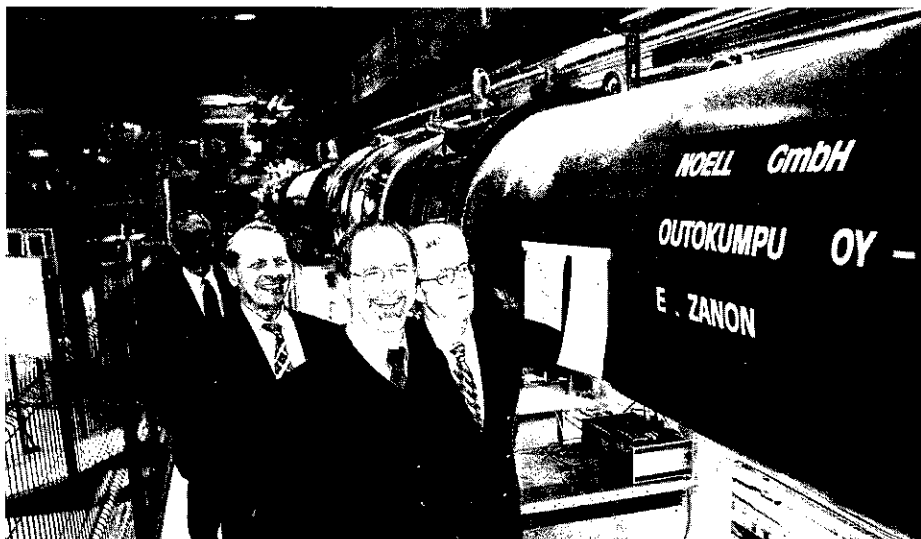

would try to preserve his logic in the pages of a notebook which one of us named "Werner's Wise Words".

The world of accelerators has lost an innovative and analytical mind but we are left with the memory of a dear colleague to whom we will forever be grateful for his clear insights and jovial friendship.

Physics goes Dutch

At the annual meeting of the Dutch NIKHEF Laboratory, Director Ger van Middelkoop, in his 'State of the Union' speech, announced an

innovation in national research funding. FOM, the Dutch organization funding physics research, henceforth assigns research centres a lump sum for each of a series of approved research programmes. The sum covers the costs of the entire programme, which can be of variable length, e.g. 2 years for research at the AmPS-accelerator in Amsterdam up to 17 years for the Dutch participation in the ATLAS experiment at CERN's LHC. Although personnel and related costs do not change radically, other expenditure may change from year to year and it is up to the institute to decide the expenditure profile over the lifetime of a



Cryogenic Components



Manufacturing Line

- Cryogenic Valves
(Shut-off and Control Valves, Vacuum Jacketed and also for Cold Box Mounting)
- Special Valves for any Cryogenic Applications (Check-Valves, Pilot Cryogenic Valves, Relief Valves etc.)
- Bellows Sealed Valves
(up to PN420)
- Cryogenic Transferlines and Couplings (Johnston and Multi-Coaxial Couplings)
- Space Cryogenic Components
- Custom made Cryogenic Components e. g. Cryostats and Ejectors

Cryogenic Control Valve >

pneumatically operated, with intelligent electro-pneumatic positioner, travel feedback and limit switches, with vacuum weld-in flange for cold box mounting

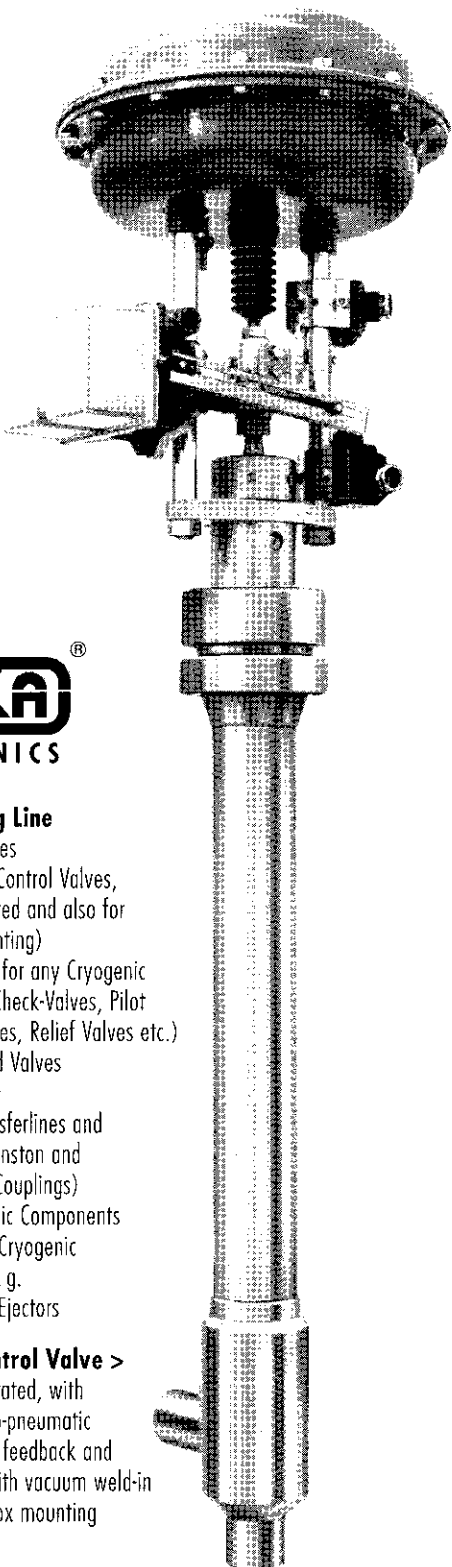

WEKA AG · Schürlistr. 8 · CH-8344 Bäretswil · Switzerland
Telefon 01 939 29 59 · Telefax 01 939 29 63

Für USA und Kanada: PROVAC LTD, POB 18411, Greensboro, North Carolina 27419
 Phone (910) 282 6618, Fax (910) 288 3375

Für Japan: NIPPON SANSO CORPORATION
 PLANT & MACHINERY DIV., SPACE & CRYOGENIC EQUIPMENT DEPT.
 6-2 Koijima-cho, Kawasaki-ku, Kawasaki-City, Kanagawa-Pref. 210, Japan
 Phone 044 (288) 4063, Fax 044 (299) 4109

Get your physic knowledge

at

www.freihofer.ch



ACADEMICA

Universitätstrasse 11
 Postfach, 8033 Zürich
 Tel. 01/363 42 88, Fax 01/261 53 92

cyberc@ve

Predigerplatz 24
 Postfach, 8033 Zürich
 Tel. 01/261 08 21, Fax 01/261 08 22

GEC ALSTHOM

A commitment to excellence in applied superconductivity

Wires

- NbTi / Cu
- NbTi / CuNi / Cu
- NbTi / CuNi
- Nb₃Sn

For

- . MRI - MRS magnets
- . Collider magnets
- . Detector magnets
- . SMES applications
- . Fusion applications

Cables

- . Aluminium jacketed conductors

AC Applications

- . Current limiters
- . Transformers
- . Generators

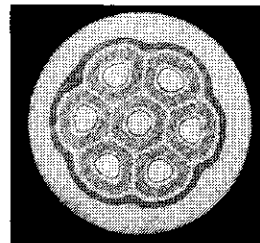

Gec Alsthom one of the world leaders in superconducting cables and wires

For any further information, please contact us



3, avenue des Trois Châteaux - 90018 Belfort Cedex, France
 Tel +33 (0)3 84 55 32 26 - Fax +33 (0)3 84 55 16 15

CERN's new Travelling Exhibition, organized by Peggie Rimmer (photo), paused this winter at CERN before resuming its tour of CERN Member States. Fully booked throughout 1998, the exhibition will be at Heureka in Vantaa, Finland, from 12 February to 22 March, Stockholm's Teknorama from 2 April to 21 June, the Teknikens Hus in Luleå, Sweden, from 2 July until 13 September, Copenhagen's Experimentarium from 24 September to 8 November and at the Teknoteket in Oslo from 19 November to January 1999.

particular programme. The 1998 commitments add up to the total NIKHEF budget, but from 2000, when some current programmes end, there will be room for new initiatives.

Meetings

The 3rd International Seminar on High Energy Physics and Thermonuclear Research commemorating the 80th anniversary of A.M. Budker and 40 years of the Budker Institute of Nuclear Physics will be held at Novosibirsk, Russia from 11-15 May. Further information from Prof. V. Baier, E-mail: binp40@inp.nsk.su and the WWW Home Page <http://www.inp.nsk.su/jubilee.en.html>



At the end of last year, as part of the annual Nuclear Physics Symposium organized by India's Department of Atomic Energy, a seminar at Bangalore University commemorated the 50th anniversary of the discovery of the pion at Bristol (June 1997, page 2).



External correspondents

- Argonne National Laboratory, (USA)
D. Ayres
- Brookhaven, National Laboratory, (USA)
P. Yamin
- CEBAF Laboratory, (USA)
S. Corneliussen
- Cornell University, (USA)
D. G. Cassel
- DESY Laboratory, (Germany)
Ilka Flegel, P. Waloschek
- Fermi National Accelerator Laboratory, (USA)
Judy Jackson
- GSI Darmstadt, (Germany)
G. Siegert
- INFN, (Italy)
A. Pascolini
- IHEP, Beijing, (China)
Qi Nading
- JINR Dubna, (Russia)
B. Starchenko
- KEK National Laboratory, (Japan)
A. Maki
- Lawrence Berkeley Laboratory, (USA)
B. Feinberg
- Los Alamos National Laboratory, (USA)
C. Hoffmann
- NIKHEF Laboratory, (Netherlands)
Margriet van der Heijden
- Novosibirsk Institute, (Russia)
S. Eidelman
- Orsay Laboratory, (France)
Anne-Marie Lutz
- PSI Laboratory, (Switzerland)
P.-R. Kettle
- Rutherford Appleton Laboratory, (UK)
Jacky Hutchinson
- Saclay Laboratory, (France)
Elisabeth Locci
- IHEP, Serpukhov, (Russia)
Yu. Ryabov
- Stanford Linear Accelerator Center, (USA)
M. Riordan
- TRIUMF Laboratory, (Canada)
M. K. Craddock



UPPSALA UNIVERSITY

The Svedberg Laboratory

In Uppsala, Sweden is inviting applications for two positions as

Senior Research Engineers

Candidates should have a Masters degree in Engineering (or equivalent). The work is to participate in development, operation, and maintenance of our accelerator facility.

One of the positions (reference number 1062/98) will be on the

Gustaf Werner Cyclotron and its Ion Sources

Knowledge and experience of electrical and electronics systems are required. Experience of ion sources and accelerators and their associated technology, in particular with high-frequency and high-voltage is desirable.

The other one (reference number 1063/98) will be connected to the

Accelerator Control System

where the work is on analog and digital hardware systems as well as with software. Excellent knowledge of C-programming and experience of low-level hardware programming are required. Experience of system programming in UNIX environment, especially with regard to computer communication, is desirable. Knowledge of C++ and experience of designing analog and digital hardware are also desirable.

Since we work on the accelerators together as a group, and have many research collaborations as users, excellent ability for teamwork is a requirement. Uppsala University has the ambition to enhance gender equality. Since most positions as senior research engineer are occupied by men, we encourage more women to apply.

Information about the laboratory can be found at <http://www.tsl.uu.se>. Further information about the laboratory and the positions can be obtained from Dag Reistad, phone no. +46 18 471 3177, fax no. +46 18 471 3833, e-mail reistad@tsl.uu.se.

The application should be made to Uppsala University and must be mailed so as to arrive at Uppsala University, Registrar's Office, Box 256, S-751 05 Uppsala, Sweden, fax no. +46 18 471 2000 no later than May 4, 1998. A fax should be followed by an application with a hand-written signature.

SENIOR ENGINEER

Electronics Design Facility

This position in the Electronics Design Facility at Boston University provides engineering support to high energy physics research projects at SLAC, CERN, Brookhaven National Laboratory, and other international sites. The successful candidate will demonstrate considerable expertise, creativity and independence in state-of-the-art electronics, including high-speed analog and digital design. Full-custom IC design experience preferred. Substantial experience with experimental physics research required. Familiarity with NIM, CAMAC, VME/VXI and FASTBUS standards a plus.

Candidates must have an MS degree in Physics, Electrical Engineering or equivalent, and 5 years related experience. The EDF is staffed by five engineers and technicians. Equipment includes a Mentor Graphics CAE system (used for IC and PCB design), modern test equipment, VMEbus and CAMAC development systems, and several computer workstations.

Please send cover letter and resume to Virginia Gregory, Boston University, Office of Personnel, 25 Buick Street, Boston, MA 02215. <http://www.bu.edu/PERSONNEL>.



An affirmative action, equal opportunity employer.



THE UNIVERSITY OF BIRMINGHAM

SCHOOL OF PHYSICS AND ASTRONOMY LECTURESHIP IN EXPERIMENTAL PARTICLE PHYSICS

Applications are invited for the above post which is available from 1 September 1998. The particle physics group has 11 permanent physicists, 13 postdoctoral physicists, 10 support staff and 10 research students. The present activities include the OPAL experiment at LEP, the H1 experiment at HERA, the NA57 heavy ion experiment at the SPS, and the ATLAS and ALICE experiments at the LHC. Further details about the group's research programme can be found on the WWW at: <http://www.bham.ac.uk/physics/ep/>

The successful candidate will be expected to contribute to the current and future research and to take part in undergraduate and graduate teaching.

Applicants should have a PhD or equivalent in particle physics and preferably several years' postdoctoral experience in the field.

Salary will be in the range £16,045 - £27,985 per annum.

Further information about the post may be obtained from Professor J D Dowell, School of Physics and Astronomy, The University of Birmingham, Edgbaston, Birmingham B15 2TT, telephone: 0121 414 4658, fax: 0121 414 6709, (e-mail: JDD@HEP.PH.BHAM.AC.UK).

Application forms (returnable by 31 March 1998) and further particulars are available from the Director of Staffing Services, The University of Birmingham, Edgbaston, Birmingham B15 2TT, telephone: 0121 414 6486, (e-mail: STAFFING@BHAM.AC.UK). Please quote reference S35062/98.

Working towards equal opportunities.

**POSTDOCTORAL RESEARCH ASSOCIATE
EXPERIMENTAL NUCLEAR PHYSICS
INDIANA UNIVERSITY**

The I.U. nuclear physics group currently performs experiments using hadronic and electromagnetic beams in the U.S., Europe, and Japan. The local program is conducted at the Indiana University Cyclotron Facility where a major upgrade of the injector for the 500 q/A electron cooled storage ring is near completion. The upgrade will provide high luminosity capability with polarized beams and targets. IUCF also provides significant infrastructure to support major offsite projects. The wide range of questions being addressed by 14 faculty members range from that of parity violation in thermal neutron-proton capture at LANSCE to investigations of the flavor and spin structure of the nucleon at RHIC with the STAR detector. Opportunities are available on all major research projects. For further information, please access our Web site at <http://www.iucf.indiana.edu>.

Initial appointments as research associate will be for one year, with possible renewal for two additional years. A Ph.D. in experimental subatomic physics is required. Applications for postdoctoral positions are accepted on a continuing basis and starting dates can be adjusted to suit the situation of the candidates.

Applications including resume, bibliography, and three references should be sent to *Dr. John M. Cameron, Director, Indiana University Cyclotron Facility, 2401 Milo Sampson Lane, Bloomington, IN 47408* (Email: cameron@iucf.indiana.edu) Indiana University is an Affirmative Action/Equal Opportunity Employer.



**DEUTSCHES ELEKTRONEN-SYNCHROTRON
DESY**

We seek an experimental physicist to play a key role in a collaborative R/D program extending the range of accelerating gradients achievable in superconducting radio frequency cavities. The work will take place at Cornell University. The successful candidate will need to be resident in Ithaca, NY, although some visits to DESY Germany will also be required.

Candidates should have a recent PhD in experimental physics or engineering physics. Experience in some of the following areas is desirable: low temperature physics, vacuum science, solid state physics, surface physics and radio frequency systems for accelerators. Excellence with oral and written communication is required, as is the ability to work both independently and as a member of a group. Candidates must be younger than 32 years of age.

The position is awarded for a duration of two years with the possibility of one additional year.

Interested persons should send their application including a resume and the usual documents (curriculum vitae, list of publications) before 24th april 1998 to:

**DEUTSCHES ELEKTRONEN-SYNCHROTRON, DESY,
Notkestraße, 85, 22607 Hamburg, Germany
Code Nr. 5/98**

They should also arrange for three letters of reference to be sent by the same date to the above address.

Handicapped applicants will be given preference to other applicants with the same qualification. Women are especially encouraged to apply for this position.



**Johann Wolfgang Goethe-Universität
Frankfurt am Main**

The Physics Department of the Johann Wolfgang Goethe University at Frankfurt / Main invites applications for a

Full Professorship (C4) of Applied Physics

The appointment is to begin in April 1999.

Research in the group focuses on physical principles and applications of particle accelerators. Applications are solicited from scientists with an outstanding record in research areas such as the physics of intense particle beams, ultrahigh-frequency physics, and the development of modern particle accelerator systems. The prospective appointee is expected to participate actively in international large-scale projects.

Teaching obligations for undergraduate students cover the entire field of experimental physics. Willingness to participate in the autonomous academic administrative system is required.

The University is seeking to raise the percentage of female members of the scientific staff and thus specifically encourages applications from women.

The formal requirements to be fulfilled by the appointee are given by § 39a HUG (Hessian University Law). The regulations are available upon request. At the time of appointment, the appointee must not be older than 52. The law requires handicapped applicants to be given preference.

Please send your resume within six weeks after appearance of this announcement to: **Dekan des Fachbereichs Physik, Johann Wolfgang Goethe-Universität, Postfach 11 19 32, D-60054 Frankfurt am Main (Postal address for parcels: Senckenberganlage 31, D-60325 Frankfurt)**

Within the HADES project GSI has available as of March 1998

**TWO POSTDOCTORAL
POSITIONS**

for Physicists with a PhD in Nuclear or Particle Physics

Main activities will be the development of the Analysis- and Simulation Software as well as the development and installation of tracking detectors.

The HADES spectrometer is presently being constructed at GSI within large European collaboration for the investigation of dilepton pair emission in relativistic heavy ion collisions. Experiments will start late in 1998. GSI has taken over responsibility for the software development as well as for the setup and coordination of the magnet and detectors. Electron identification is achieved using RICH and tracking detectors. Analysis programs are being written in C++ in a UNIX environment utilizing ROOT and GEANT as analysis and simulation packages. A computer network based on DEC/ALPHA, LINUX and IBM/AIX workstations is available.

The positions are within the FPI research division at GSI and are limited to a period of three years. Salary and fringe benefits will be according to the German BAT, index IIa. Please direct all inquiries to:

Peter Braum-Munzinger,
GSI, Planckstr. 1
D-64291 Darmstadt

Internet:
P.Braum-Munzinger@gsi.de
Tel.: 49-6159-712760/2761
Fax: 49-6159-712989

CES PRESENTS:

Two major building blocks for the next generation of DAQs

A general-purpose detector read-out card

MFCC 8441

- Detector input
128-bit wide
100 Mbytes/s
- On-board Computing Kernel
PowerPC 603ev or Arthur 133 MHz to 200 MHz
16 or 64 Mbytes SDRAM
2 Mbytes Flash EPROM
- CES Optimized PowerPC / PCI bridge
Independent chained DMA channels
I2O message passing mechanism
- Comprehensive set of software tools and services

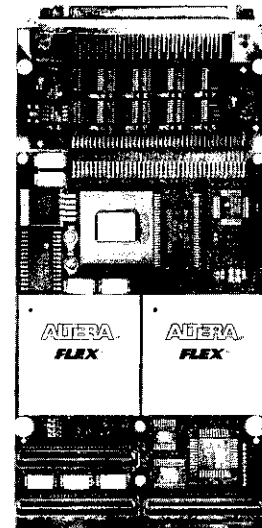

Up to 6 MFCC 8441 can be attached to a single RIO2 8062 processor.

PVIC 8425

A transparent PCI to PCI link at full PCI speed

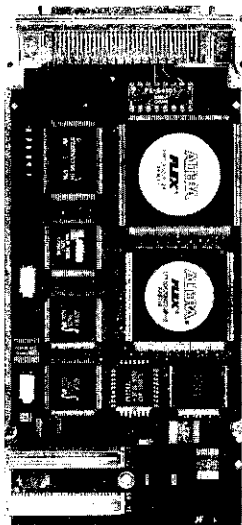

- Fully transparent byte, word, long-word transactions
- Full PCI-speed traffic at 132 Mbytes/s bandwidth
- Support for interprocessor communication
- Hardware test and set mechanism
- Advanced interrupt dispatching logic for remote and local interrupt handling
- On-board autonomous block mover offering chained DMAs executed concurrently with the transparent mode
- Unique set of advanced broadcast modes
- Libraries and drivers optimized for real-time (Lynx-OS, VxWorks)
- Comprehensive set of software libraries

With the PVIC 8425 any number of MFCC 8441 can be interconnected at full PCI speed.



Your Real-Time Partner



For any additional information about this product or our complete PowerPC, PMC, Connections, VME, CAMAC and FASTBUS line, do not hesitate to contact us.

CES Geneva, Switzerland Tel: +41-22 792 57 45 Fax: +41-22 792 57 48 EMail: ces@ces.ch
CES.D Germany Tel: +49-60 55 4023 Fax: +49-60 55 82 210
CES Creative Electronic Systems SA, 70 Route du Pont-Butin, CH-1213 Petit-Lancy 1, Switzerland
Internet: <http://www.ces.ch>

